

# **YDC3300**

# **Maintenance manual**

Confidential document

**Shenzhen Kstar Science & Technology Co.,Ltd**

## Contents

Contents .....	I
FigureContents .....	III
Table contents .....	IV
1. Product introduction .....	1
1.1 Summary .....	1
1.2 Appearance .....	1
1.3 Features .....	2
1.4 Operating panel .....	2
2 System block diagram .....	4
2.1 block diagram .....	4
2.2 AC/DC & DC/DC principle circuit diagram .....	4
2.3 Inverter DC/AC principle .....	5
2.4 Charging principle .....	6
3 Parameters .....	6
3.1 UPS specification .....	6
4 Internal structure .....	8
4.1 The whole appearance .....	8
4.2 Internal view of UPS .....	11
5 PCB boards and their signals .....	20
5.1 PFC inductor board .....	20
5.2 PFC drive board .....	22
5.3 PFC power board .....	24
5.4 INV. Inductor board .....	25
5.5 Inverter power board .....	28
5.6 DSP board .....	29
5.7 Adapter board .....	31
5.8 RJ45 interface board .....	31
5.9 EPO interface board .....	32

5.10	USB interface board.....	32
5.11	parallel interface board .....	33
6	Inspection before installation.....	34
6.1	Room environment inspection.....	34
6.2	UPS location inspection .....	34
6.3	UPS visual inspection.....	34
6.4	External cables and switch capacity inspection.....	34
6.5	External auto switching and generator power distribution inspection.....	35
6.6	Battery inspection .....	35
7	UPS maintenance .....	36
7.1	Guidelines for good service .....	36
7.2	Security conditions .....	37
7.3	Shutdown-disassembly/reassembly UPS.....	37
7.4	Troubleshooting .....	38
8	Battery replacement.....	43
9	PCB replacement .....	44
10	Replace fan .....	47
11	PCB static maintenance.....	47
12	Stand-alone commissioning .....	48
12.1	Startup steps.....	48
12.2	Shutdown steps: .....	49
12.3	Emergency shutdown instructions .....	49
12.4	Parameters setting .....	49
13	Parallel system commissioning.....	58
13.1	Boost steps .....	58
13.2	Shutdown steps .....	59
13.3	Emergency shutdown .....	60
14	Software upgrade.....	60
14.1	Use C2000 emulator to upgrade .....	60
14.2	Use RS232 port to realize online upgrade .....	60

**FigureContents**

Figure 1 Appearance .....2

Figure 2. Operating interface .....3

Figure 3 block diagram.....4

Figure 4 AC/DC & DC/DC principle .....5

Figure 5 Bypass and inverter principle .....5

Figure 6. Charging principle .....6

Figure 7. UPS front view .....8

Figure 8. UPS rear view (10-20K) .....9

Figure 9. UPS rear view (30-40K).....10

Figure 10. Terminal block (10-20K).....10

Figure 11. Terminal block (30-40K) .....11

Figure 12.UPS left view (10K) .....11

Figure 13.UPS right view (10K) .....12

Figure 14.UPS left view (15-20KVA) .....12

Figure 15.UPS right view (15-20KVA) .....13

Figure 16.UPS left view (30KVA) .....13

Figure26. Inverter inductor board (10K).....17

Figure27. Inverter inductor board (15-20K).....17

Figure28. Inverter inductor board (30K).....17

Figure29. Inverter inductor board (40K).....18

Figure 30. INV. Power board.....18

Figure 31. Control detection board .....18

Figure 32. Battery EMI board .....18

Figure 33. EMI board (10-20K) .....19

Figure 34. EMI board (30-40K) .....19

Figure 35.PFC drive board .....19

Figure 36. Adapter.....19

Figure 37.RJ45 interface board .....20

Figure 38.EPO interface board .....20

Figure 39.USB interface board .....20

Figure 40. parallel interface board .....20

Figure 41. PFC inductor board .....21

Figure 42.PFC drive board interface .....23

Figure 43PFC power board .....24

Figure 44 Inv. Inductor board (10K).....25

Figure 45 Inv. Inductor board (15-20K).....26

Figure 46 Inv. Inductor board (30K).....26

Figure 47 Inv. Inductor board (40K).....26

<i>Figure 48 Inverter power board</i> .....	28
<i>Figure 49 DSP board</i> .....	29
<i>Figure 50. adapter interface</i> .....	31
<i>Figure 51.RJ45 interface board interface</i> .....	31
<i>Figure 52.EPO interface board interface</i> .....	32
<i>Figure 53 .USB interface board interface</i> .....	33
<i>Figure 54.parallel interface board interface</i> .....	33

### Table contents

<i>Table 1 Indicator description</i> .....	3
<i>Table 2 Button description</i> .....	3
<i>Table 3 YDC3300 data sheet</i> .....	6
<i>Table 4 PFC inductor board interface</i> .....	21
<i>Table 5 PFC drive board interface description</i> .....	23
<i>Table 6 PFC power board interface</i> .....	24
<i>Table 7 Inv. Inductor board interface</i> .....	26
<i>Table 8 Inv. Power board interface</i> .....	28
<i>Table 9 DSP board interface</i> .....	29
<i>Table 10 adapter board interface</i> .....	31
<i>Table 11 RJ45 interface board interface</i> .....	32
<i>Table 12 EPO interface board interface</i> .....	32
<i>Table 13 USB interface board interface</i> .....	33
<i>Table 14 parallel interface board interface</i> .....	33
<i>Table 15 Common fault troubleshooting</i> .....	40

# YDC3300 Maintenance manual

## 1. Product introduction

### 1.1 Summary

YDC3300 Series is a kind of high-frequency online intelligent UPS and adopts double DSP control chips, advanced control technology and double conversion topology. It eliminates various interference of the grid and makes the output a stable and pure sine wave power with low noise, no interference and low distortion. With strong load capacity, good load compatibility, wide input voltage and frequency range, excellent generator compatibility and zero transfer time, it greatly meets the requirement of variety of applications. Comprehensive protection enhances the stability and reliability of the system. Intelligent battery management, equalized and floating charging auto conversion, battery discharge time prediction and battery self-test can extend the battery life. It can be used in advanced network systems.

- ★ power range: 10KVA-40KVA, up to 4 units can be parallel,
- ★ Working mode: High frequency intelligent online (3-phase in to 3-phase out)
- ★ Application: Work station, network server, and computer rooms and data center

### 1.2 Appearance



### 1.3 Features

◆ Three-phase in to three-phase out UPS

This series is three-phase in to three-phase out UPS with large capacity, the input current of three phase is balanced which can balance the load of each phase.

◆ Digital control

Digital control is used for all parts of the UPS, which makes the performance indicators very excellent and the system more stable. It not only has self-protection and fault diagnosis, but also can avoid risks of analog device failure, which allows the control system more reliable.

◆ Settable charging current

By setting the battery capacity configured by user, the reasonable charging current can be automatically allocated. Constant voltage charging mode, constant current charging mode and floating charging mode can auto-switch smoothly.

◆ Intelligent charging method

Advanced two-way, three-stage charging method is adopted. At the first stage, fast recharge with constant large current to 90% capacity; at the second stage, constant voltage charge can activate the battery characteristics and make the battery full; at the third stage, floating mode operates. This method can provide a balance between the fast charge and extended the battery life, which saves the battery investment.

◆ LCD display

Both the LCD and LED display for the series allows the users a more intuitive understanding of the UPS status and operating parameters such as input/output voltage and frequency, load capacity, battery capacity, temperature and ect.. All the operation are under the monitoring.

◆ Intelligent monitoring function

When SNMP is selected with UPS, the remote monitoring can be achieved easily.

◆ EPO function

An emergency power off(EPO) button interface is embedded in the rear panel of the UPS. The user can add the EPO button. In case of emergency, press the EPO button can shut down the UPS. It also has remote emergency power off (REPO) function.

### 1.4 Operating panel



Figure 2. Operating interface

◆ **Status indicator on front panel, LCD and other buttons**

LCD and indicator LED on front panel, cooperate with buttons, can view all the data, information and set parameters.

Table 1 Indicator description

Name	Status	Description
Alarm LED	Red on	UPS fault and alarm
	Red off	UPS normal
Bypass LED	Green on	UPS bypass output
	Green flash	Bypass abnormal or out of range, or bypass switch fail
	Green off	Bypass normal, no bypass output
Battery LED	Green on	Battery supply power
	Green flash	Battery discharge termination and pre-inform
	Green off	Battery abnormal(no battery or battery fail)
Mains output LED	Green on	mains output
	Green off	no mains output

Table 2 Button description

Button Name	Description
Cycle	Enter the menu to view the UPS data and information
ON	Start inverter battery cold start under the shutdown
OFF	Shut down inverter in Line mode and transfer to bypass(if bypass normal) ; Shut down inverter under the battery mode, UPS down; Battery cold start when off status

## 2 System block diagram

### 2.1 block diagram

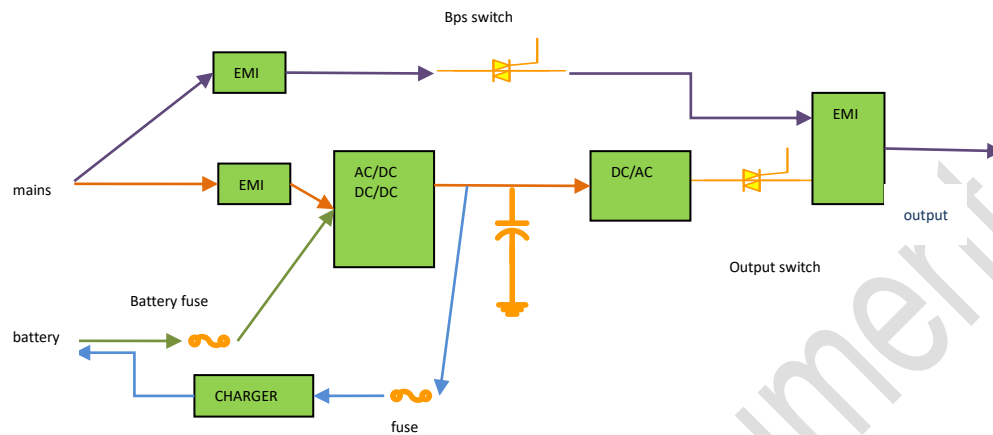

Figure 3 block diagram

As shown above, there is a bypass switch. When switch on it, the power will go to the bypass road. Then UPS will detect the output switch and bypass voltage, frequency and phase sequence. If output switch is on, both the voltage and frequency of bypass are in the range, the UPS will send out bypass output commands and meanwhile the bypass LED will be on.

Close the main switch, if the mains voltage, frequency and phase sequence are in the range, UPS will soft start. When bus voltage rises around 170V, PFC boost begins to work and the bus voltage will be up to about 250V. Inverter starts. When inverter is ready, it will transfer to inverter mode. If bypass voltage, frequency and phase sequence are normal, the inverter voltage will track the bypass power and switch to inverter output without interruption, or the UPS will transfer to inverter intermittently. Inverter LED on and bypass LED off, the inverter will provide power. If the battery is normal, the UPS will activate the charger to charge the battery.

UPS detects maintenance air-switch at any time. When remove the baffle of the switch, UPS will transfer to bypass status. Now close the maintenance air-switch for supplying power from bypass. When finish maintenance, the air-switch cannot be open until the UPS is in bypass, or it will cause the power down of load.

### 2.2 AC/DC & DC/DC principle circuit diagram

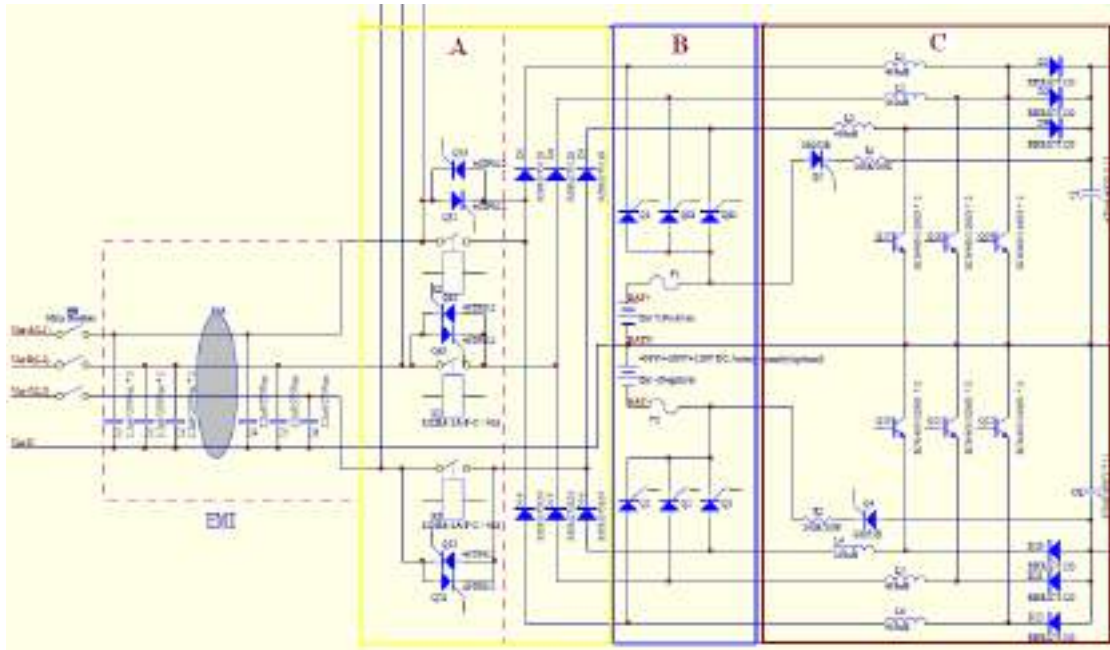

Figure 4 AC/DC & DC/DC principle

As shown above, A (yellow box) shows the rectifier circuit, B (blue box) shows the battery input circuit, C (other part) shows the boost circuit. A and C form the PFC rectifier circuit while B and C form the battery boost circuit.

### 2.3 Inverter DC/AC principle

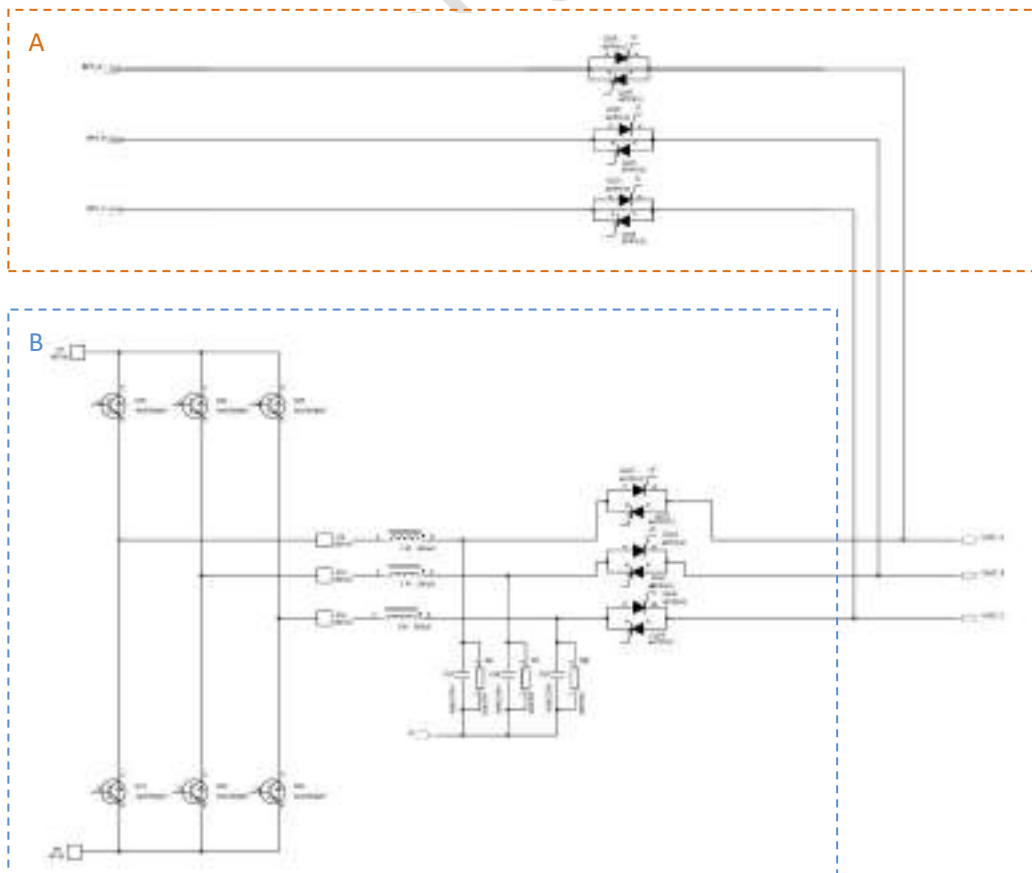

Figure 5 Bypass and inverter principle

As shown above, A (yellow box) represents bypass circuit of UPS, B (blue box) shows the inverter circuit, which converts the Bus voltage into the AC output.

### 2.4 Charging principle

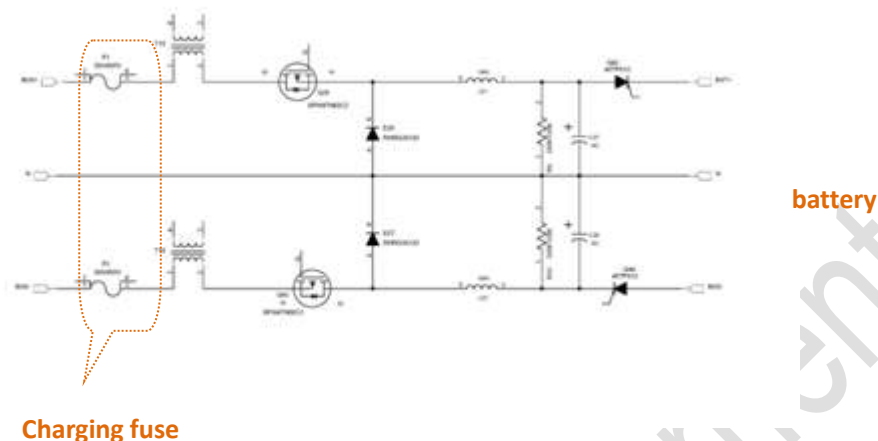

Figure 6. Charging principle

As shown above, charger reduces the Bus voltage to a suitable voltage to charge the battery.

## 3 Parameters

### 3.1 UPS specification

Table 3 YDC3300 data sheet

Model		10KVA(S/H)	15KVA(S/H)	20KVA(S/H)	30KVA(S/H)	40KVA(S/H )
Capacity		10KVA/9kW	15KVA/13.5kW	20kVA/18kW	30kVA/27kW	40kVA/36kW
		10KVA/10kW	15KVA/15kW	20kVA/20kW	30kVA/30kW	40kVA/40kW
Input	Phase	380/400/415Vac, (3Ph+N+PE)				
	Rated Voltage	380/400/415Vac				
	Voltage Range	305~478Vac (Full load); 208~478Vac (50% Load)				
	Frequency Range	40-70Hz				
	Power Factor	0.99				
	Current THDi	≤3%(100% nonlinear load)				
	Bypass Voltage Range	Max.voltage: 220Vac: +25%(optional +10%,+15%,+20% ) 230Vac: +20%(optional +10%,+15% ) 240Vac: +15%(optional +10% ) Min. voltage: -45% (optional -20%、-30%) Frequency protection range: ±10%				
	Generator Input	Support				
Output	Phase Balance	120° ±1° (100% unbalanced load)				
	Rated Voltage	380/400/415Vac, (3Ph+N+PE)				

		Power Factor	0.9/1.0			
		Voltage Regulation	±1%			
Frequency	Utility Mode	synchronize with input; when input frequency > ±10% (±1%/±2%/±4%/±5% optional), output (50/60±0.1%)Hz.				
	Battery Mode	(50/60±0.1%)Hz				
		Crest Factor	3:1			
		THD	≤2% with linear load ≤5% with non linear load			
<b>Efficiency</b>		≥93.5% at normal mode	≥94.5% at normal mode			
<b>Battery</b>	Voltage	Standard unit: ±120Vdc (2x20pcs 12V9AH;3x20pcs 12V9AH optional)	Standard unit: ±120Vdc (2x20pcs 12V9AH) ; (3x20pcs 12V9AH optional)	Standard unit: ±120Vdc (3x20pcs 12V9AH)	Standard unit: ±180Vdc (2x30pcs 12V9AH)	
	Charge Current(A) (charge current can be set according to battery capacity installed)	Standard unit: 1.35A (2.7A optional); Long run unit: Max. current 14A (limited by input current)	Standard unit: 2.7A (4.05A optional); Long run unit: Max. current 16A (limited by input current)	Standard unit: 2.7A (4.05A optional); Long run unit: Max. current 18A (limited by input current)	Standard unit: 4.05A; Long run unit: Max. current 20A (limited by input current)	Standard unit: 2.7A; Long run unit: Max. current 20A (limited by input current)
<b>Transfer Time</b>		Utility to Battery : 0ms; Utility to bypass: 0ms				
<b>Protection</b>		short circuit, overload, over temperature, battery low, fan fault alarm.				
<b>Alarms</b>	Audible & Visual	overload, utility abnormal, UPS fault, battery low, etc.				
<b>Communication Interface</b>		USB, RS232,RS485, Parallel port, Dry contact, Intelligent slot, SNMP card (optional), Relay card (optional),Battery temperature sensor(optional)				
<b>Environment</b>	Operating Temperature	0℃~40℃				
	Storage Temperature	-25℃~55℃				
	Humidity	0~95% non condensing				

	Altitude	< 1500m. When > 1500m, lower the rated power for use				
Other	Unit Dimensions(W×D×H)	Standard unit: 250×900×868 Long run unit: 250×580×655				
	Weight (Kg)	129/35	186/39	187/40	236/43	239/46
Safety Conformance		IEC/EN62040-1, IEC/EN60950-1				
EMC		IEC/EN62040-2, IEC61000-4-2, IEC61000-4-3, IEC61000-4-4, IEC61000-4-5, IEC61000-4-6, IEC61000-4-8				

## 4 Internal structure

### 4.1 The whole appearance



Figure 7. UPS front view

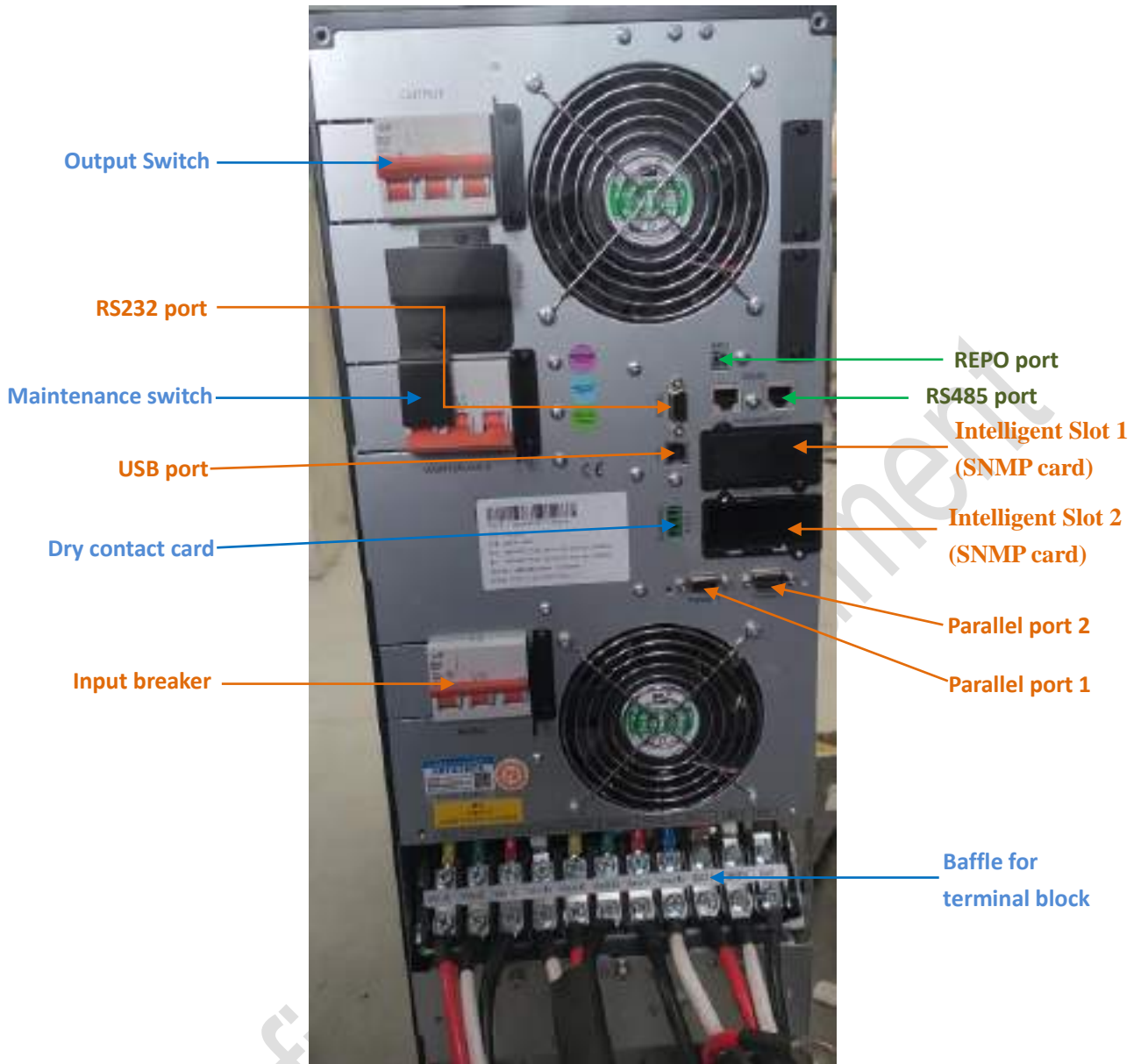

Figure 8. UPS rear view (10-20K)

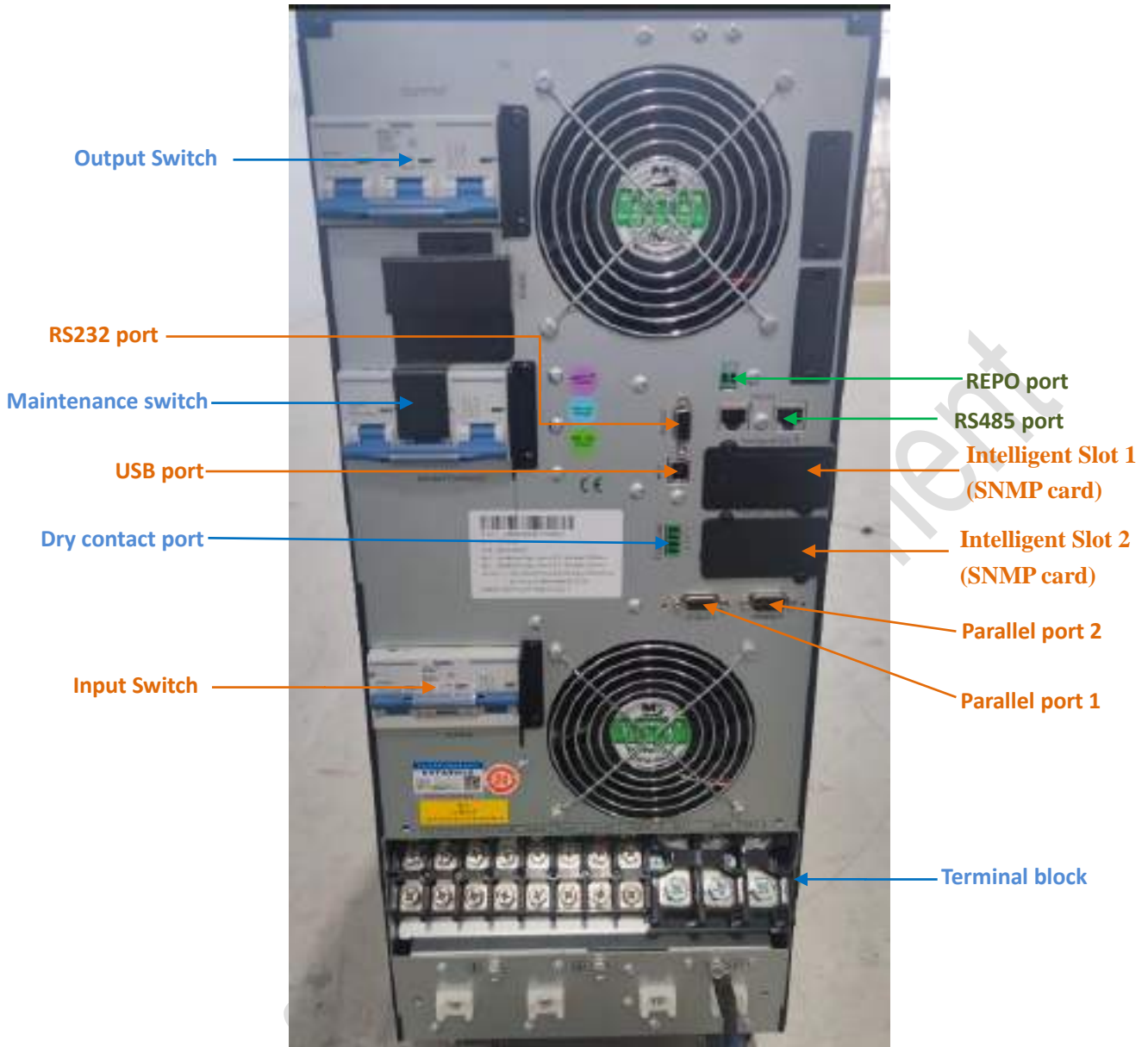

Figure 9. UPS rear view (30-40K)



Figure 10. Terminal block (10-20K)



**Terminal block**

Figure 11. Terminal block (30-40K)

4.2 Internal view of UPS

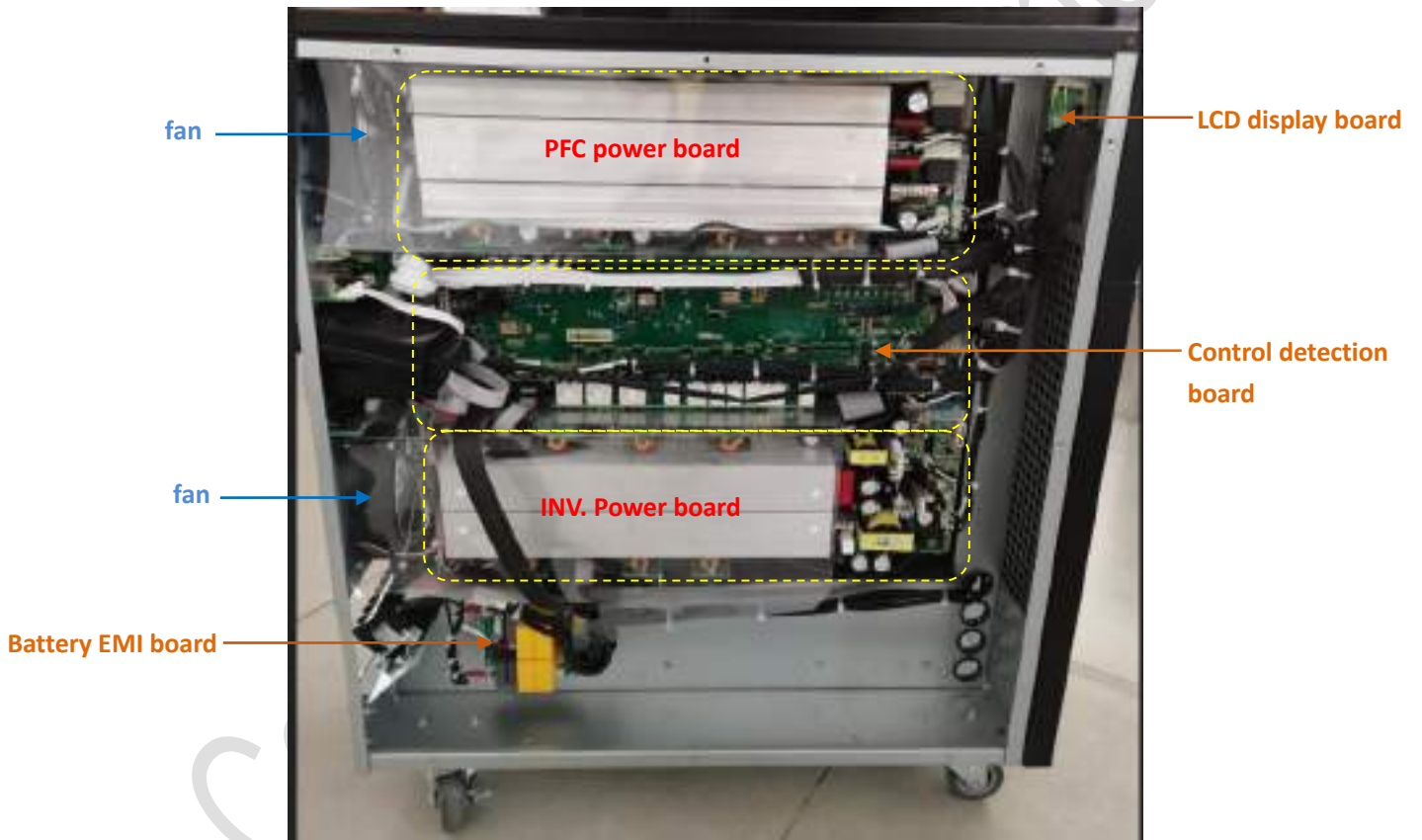

Figure 12. UPS left view (10K)



Figure 13. UPS right view (10K)

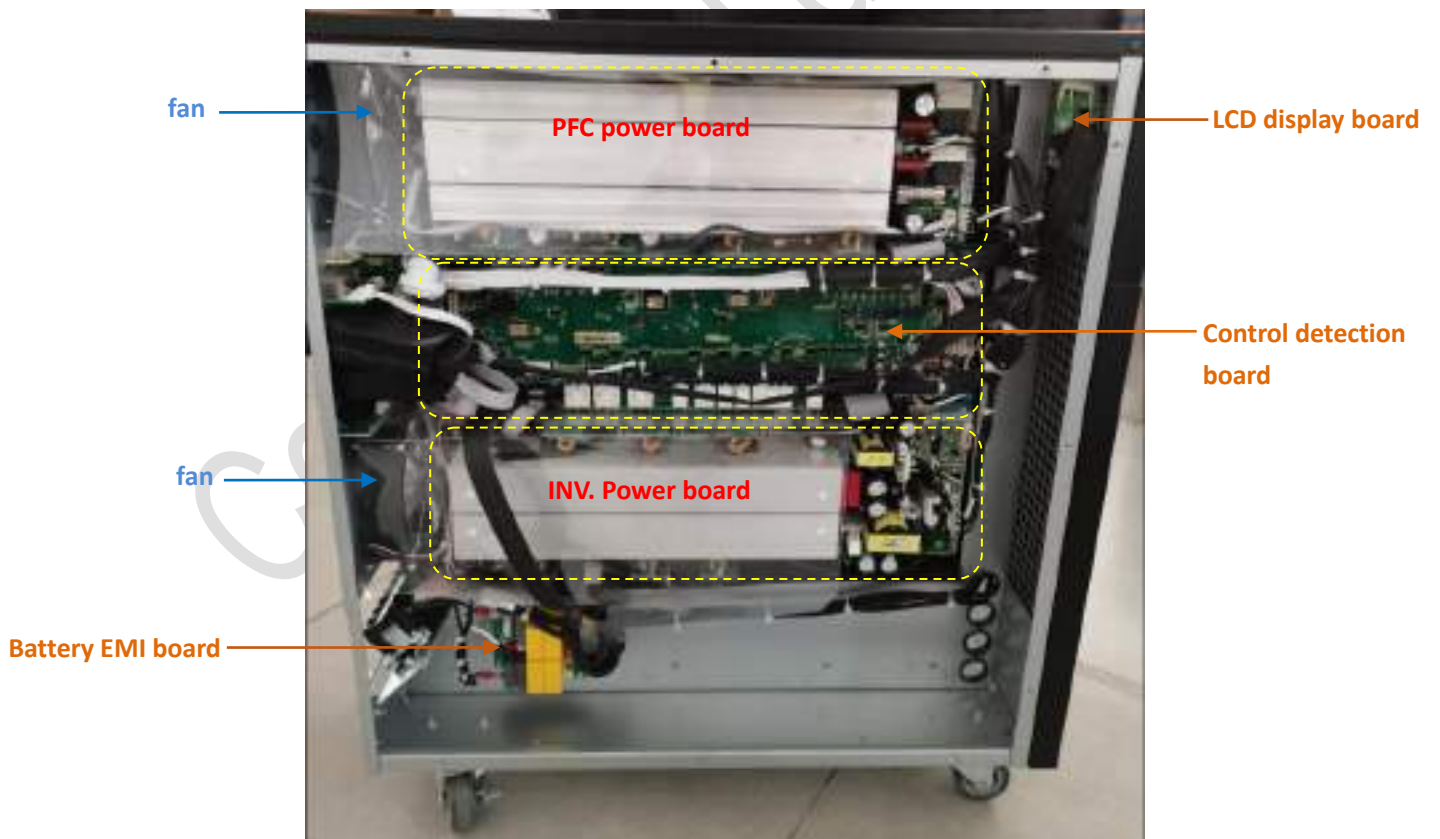

Figure 14. UPS left view (15-20KVA)

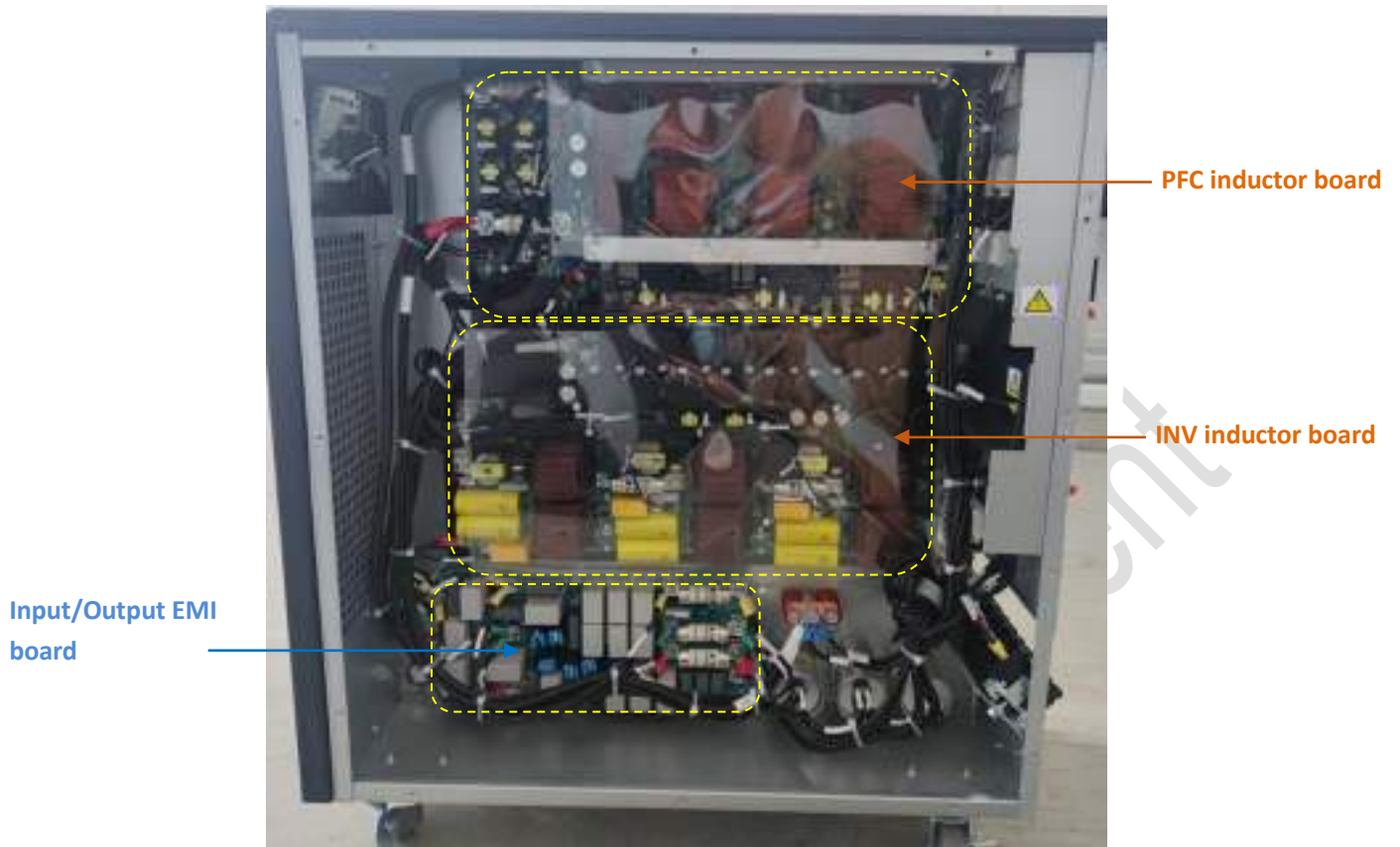

Figure 15. UPS right view (15-20KVA)

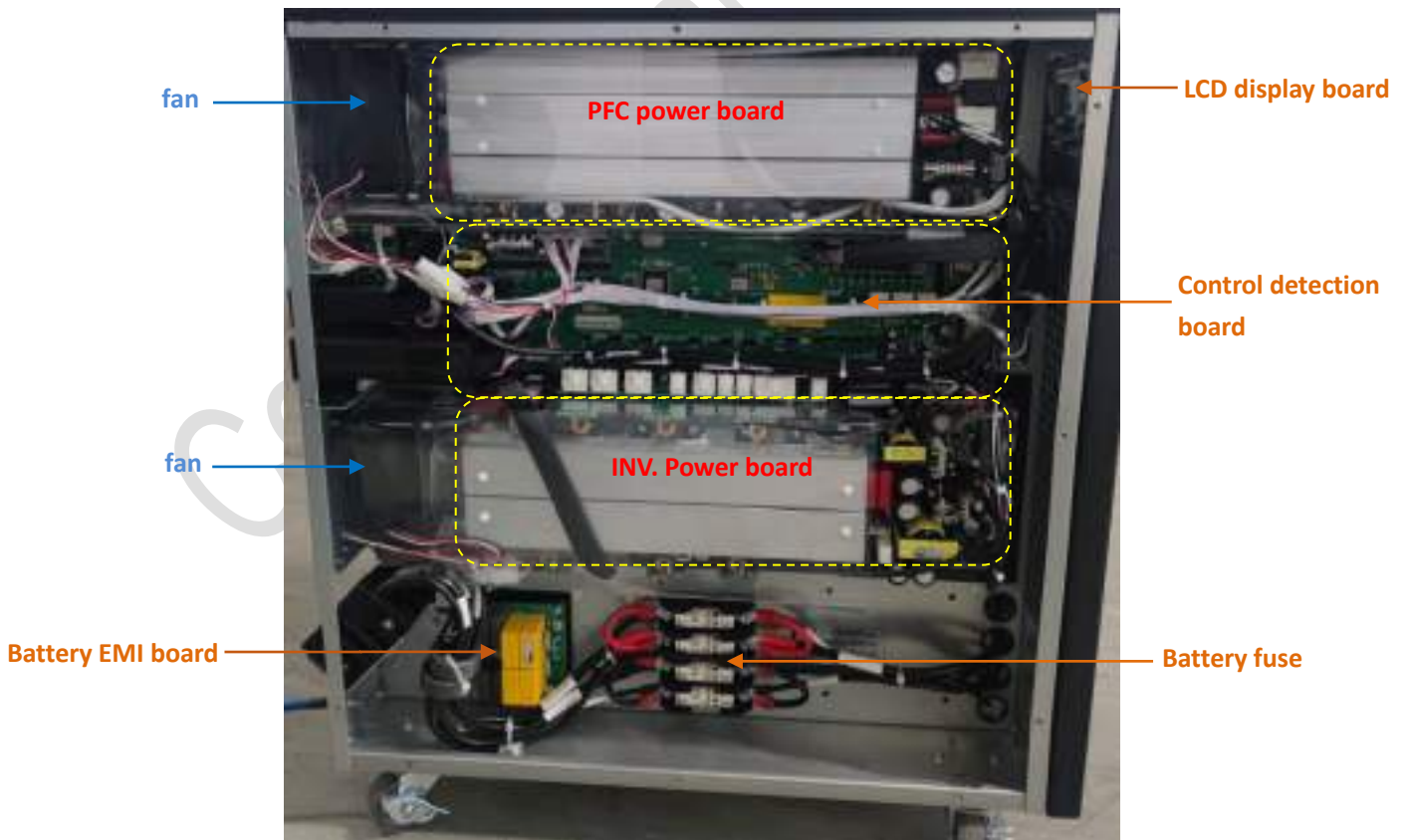

Figure 16. UPS left view (30KVA)

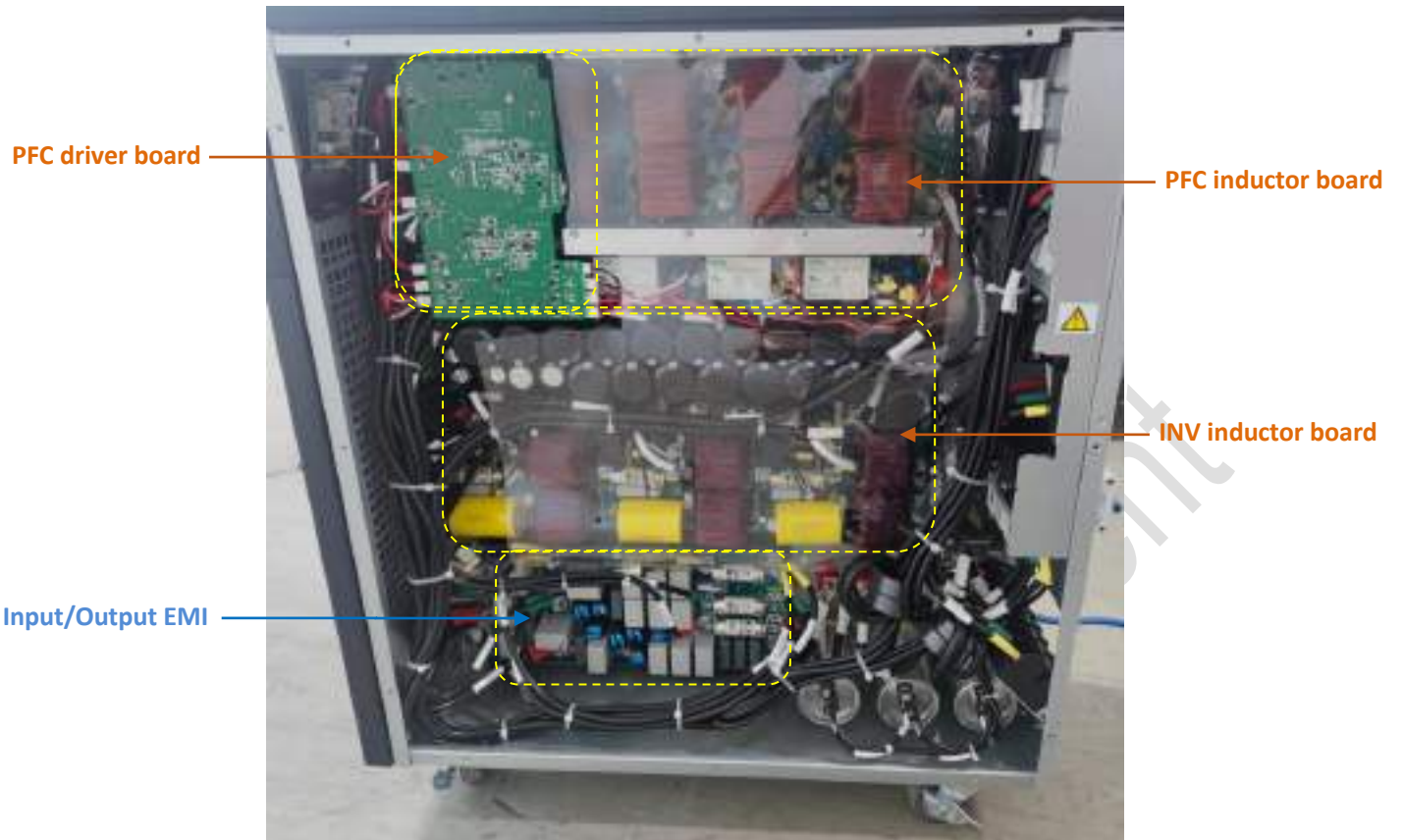

Figure17.UPS right view (30KVA)

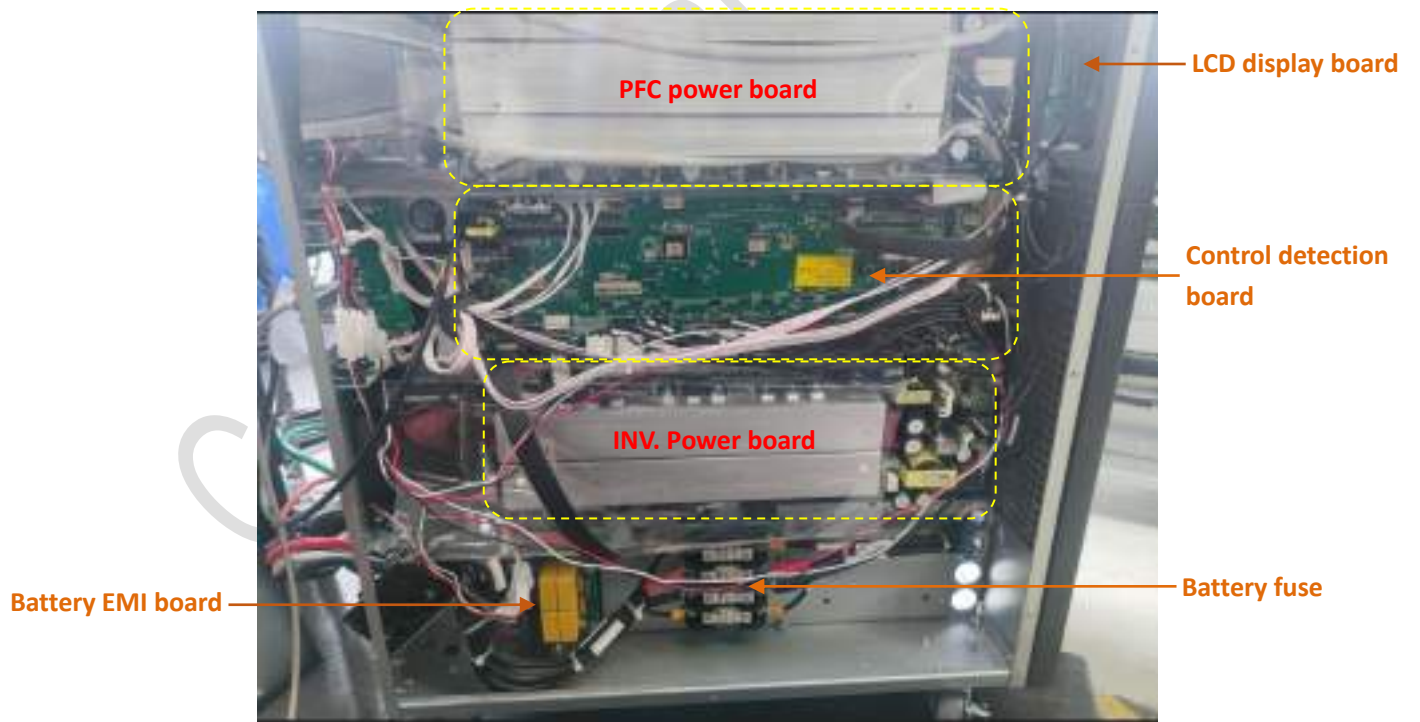

Figure18.UPS left view (40KVA)

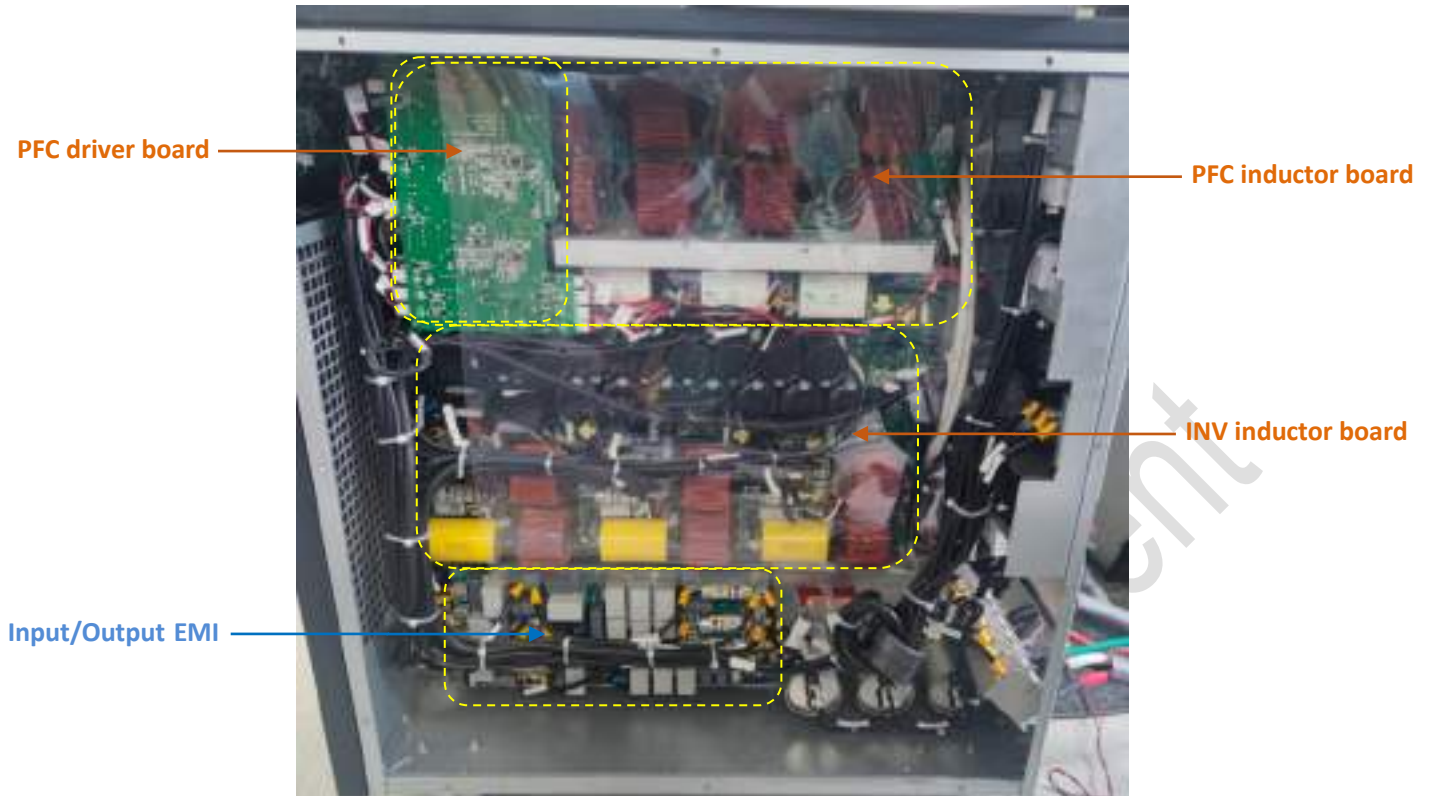

Figure19.UPS right view (40KVA)

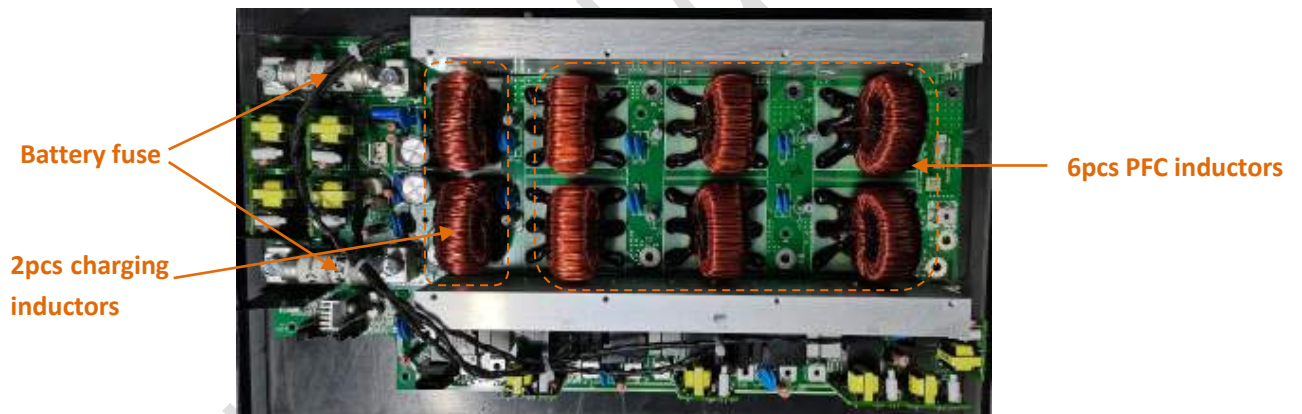

Figure20.PFC inductor board (10K)

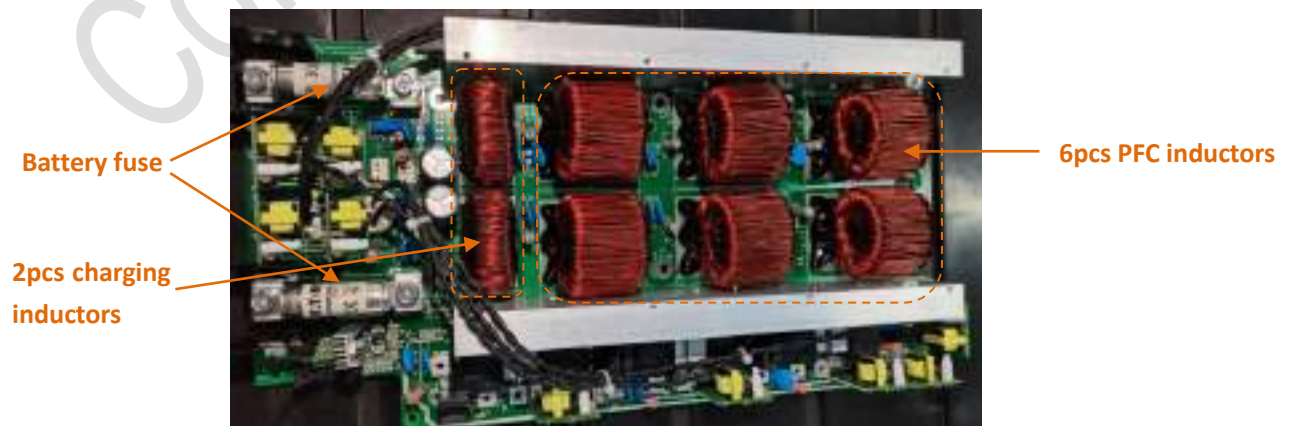

Figure21.PFC inductor board (15-20K)

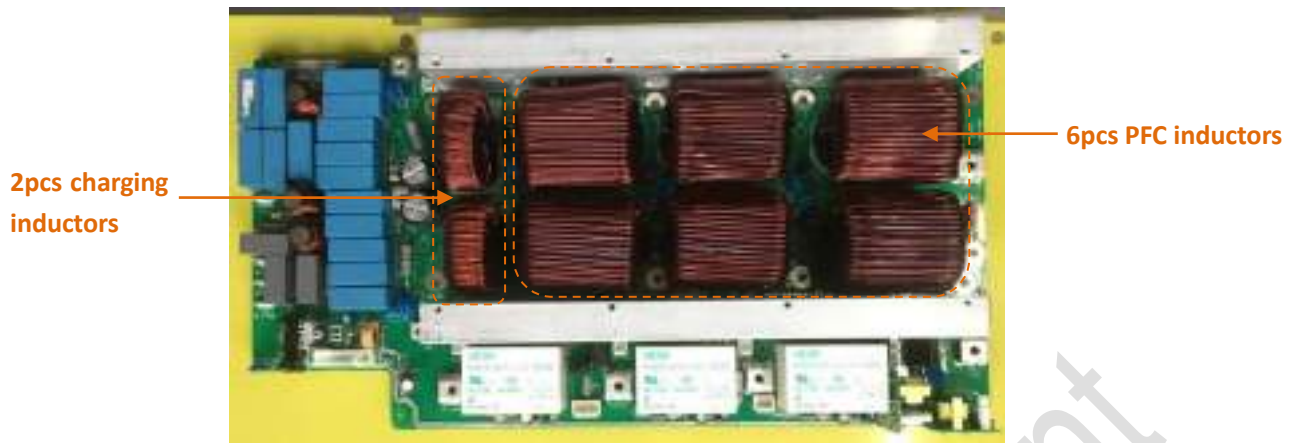

Figure22.PFC inductor board (30-40K)

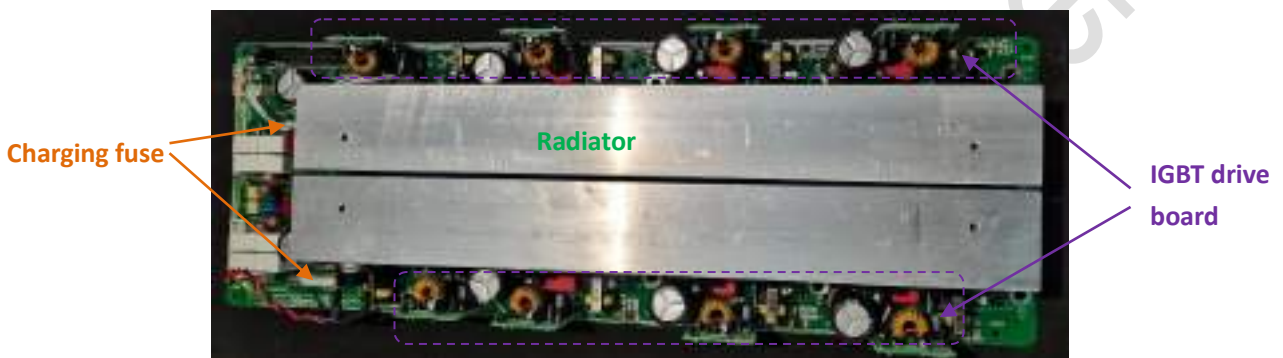

Figure23.PFC power board (10K)



Figure24.PFC power board (15-20K)

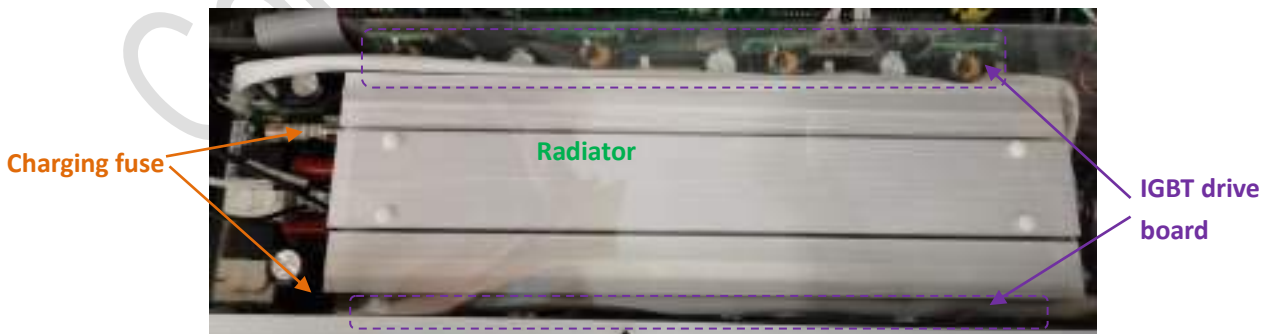

Figure25.PFC power board (30-40K)



Figure17. Inverter inductor board (10K)



Figure18. Inverter inductor board (15-20K)

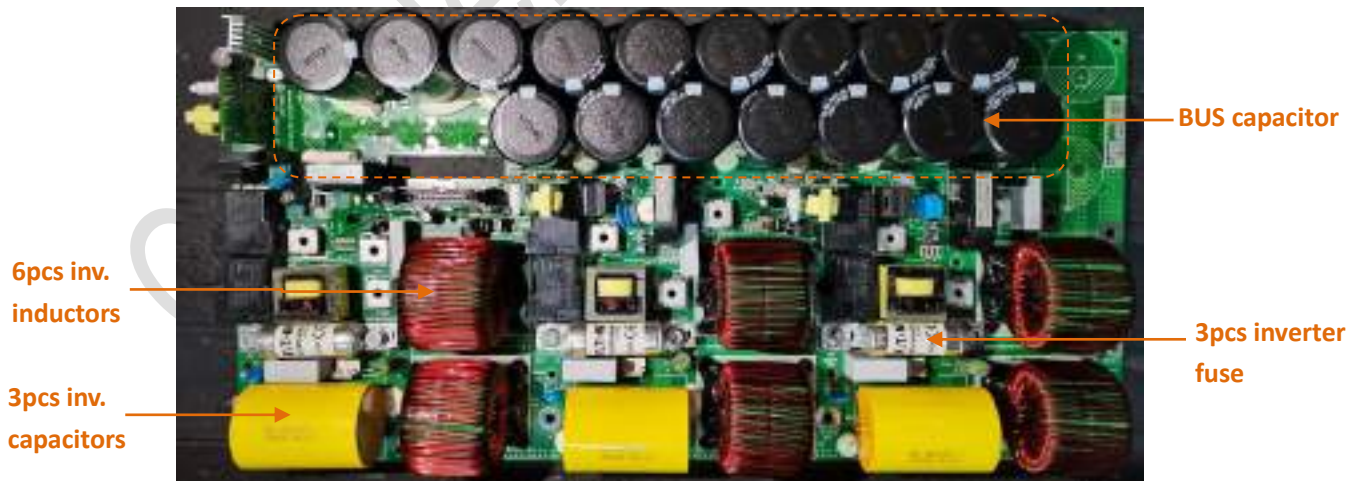

Figure19. Inverter inductor board (30K)



Figure20. Inverter inductor board (40K)



Figure 1. INV. Power board



Figure 2. Control detection board

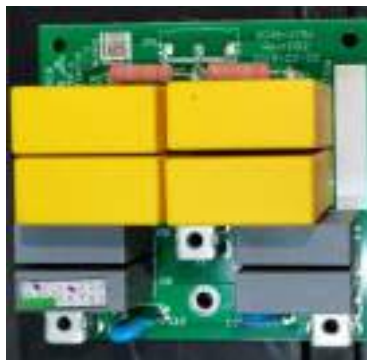

Figure 3. Battery EMI board



Figure 4. EMI board (10-20K)



Figure 5. EMI board (30-40K)



Figure 6. PFC drive board



Figure 7. Adapter



Figure 8. RJ45 interface board

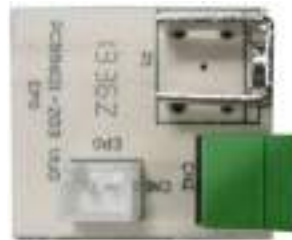

Figure 9. EPO interface board

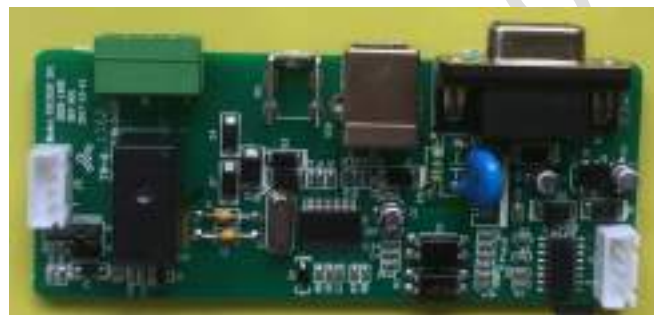

Figure 10. USB interface board

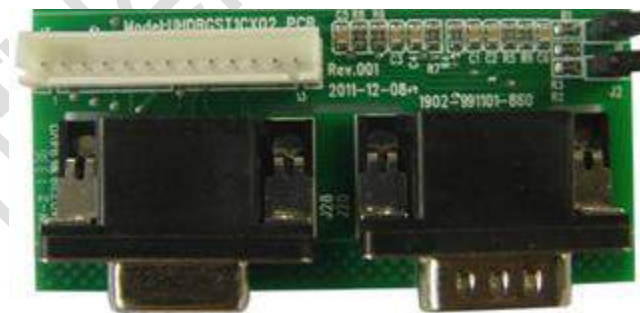

Figure 11. parallel interface board

## 5 PCB boards and their signals

### 5.1 PFC inductor board

Function overview

- Mains rectifier
- Battery input circuit

- Bypass static switch
- Boost inductor circuit
- Charging inductor circuit



Figure 12. PFC inductor board

### Input and output interface definition

Table 4 PFC inductor board interface

No.	Definition	Specification	Name	Description
P2	BAT+	Name: Copper connection Description: HPM3350-RM Copper 1 red copper T2 T=1.5mm Fog tin	BAT+	Battery fuse lock terminal
P4	BAT-	Name: Copper connection Description: HPM3350-RM Copper 1 red copper T2 T=1.5mm Fog tin	BAT-	Battery fuse lock terminal
P6	Assistant power 15V+	Name: neilsbed Description: 1121s-1 *2P 2PIN P=3.96mm 180 degree single row PIN white	Assistant power	15V+
J1	PFC drive board signal	Name: neilsbed Description: UHS65M6.PCB YDC3380 RoHS		PFC drive board signal
P15	relay/SCR drive signal	Name: neilsbed Description: 301S-2*5P 10PIN P=2.54mm 180 degrees double row square PIN black		relay/SCR drive signal
P5	BAT+ BAT+ input	Name: blade terminal Description: 4PIN 60A M4 threaded straight foot copper mist tin plating	BAT+	BAT+ input
P21	CHARGE+ CHARGE- Charging voltage sample	Name: neilsbed Description: 1121s-1 *3P 3PIN P=3.96mm 180 degrees single row PIN white	CHARGE+ CHARGE-	Charging voltage sampling
P22	BATTERY dection	Name: neilsbed Description: 1121S-3P P=3.96mm 180° single row square	BATTERY dection	BATTERY dection

No.	Definition	Specification	Name	Description
		PIN white		
P25	N Neutral	Name: neilsbed Description: 4PIN 60A M4 threaded straight foot copper mist tin plating	N	Neutral
J2	A Main A phase input	Name: neilsbed Description: 4PIN 60A M4 threaded straight foot copper mist tin plating	A	Main A phase input
J13	B Main B phase input	Name: neilsbed Description: 4PIN 60A M4 threaded straight foot copper mist tin plating 9.2*11.1*10.5mm	B	Main B phase input
J14	C Main C phase input	Name: neilsbed Description: 4PIN 60A M4 threaded straight foot copper mist tin plating 9.2*11.1*10.5mm	C	Main C phase input
J23	A Main A phase input sampling	Name: neilsbed Description: 1121s-1 *3P 3PIN P=3.96mm 180 degrees single row PIN white	A	Main A phase input sampling
J24	B&C Main B&C phase input sampling	Name: neilsbed Description: 1121s-1 *4P 4PIN P=3.96mm 180 degrees single row PIN yellow	B&C	Main B&C phase input sampling
J4	Negative charger SCR drive	Name: neilsbed Description: UHS6SM6.PCB YDC3380 RoHS	CHRG_SCR-	Negative charger SCR drive
J8	Positive battery SCR drive 1	Name: neilsbed Description: UHS6SM6.PCB YDC3380	BAT1+SCR	Positive battery SCR drive 1

## 5.2 PFC drive board

Function overview:

- Bypass SCR drive circuit
- Battery SCR drive circuit
- Charging SCR drive circuit



Figure 13.PFC drive board interface

Input and output interface definition

Table 5 PFC drive board interface description

No.	Definition	Specification	Name	Description
J1	PFC drive board signal	Name: neilsbed Description: 1121S-6P P=3.96mm 180 degree single row square PIN white		PFC drive board signal
J13	positive charger SCR drive	Name: neilsbed Description: 2001R-1*2P 2PIN P=2.54mm 90 ° Single Row PIN White	CHRG_SCR+	positive charger SCR drive
J14	negative charger SCR drive	Name: neilsbed Description: 2001S-2P P=2.54mm 180 degree single row square PIN white	CHRG_SCR-	negative charger SCR drive
J9	negative battery SCR drive1	Name: neilsbed Description: 2001S-2P P=2.54mm 180 degree single row square PIN white	BAT1-SCR1	negative battery SCR drive1
J11	negative battery SCR drive2	Name: neilsbed Description: 2001S-2P P=2.54mm 180 degree single row square PIN white	BAT1-SCR2	negative battery SCR drive2
J12	negative battery SCR drive3	Name: neilsbed Description: 2001S-2P P=2.54mm 180 degree single row square PIN white	BAT1-SCR3	negative battery SCR drive3
J6	positive battery SCR drive1	Name: neilsbed Description: 1121R-1*2P 2PIN P=3.96mm 90 degree single row PIN yellow	BAT1+SCR	positive battery SCR drive1
J7	positive battery SCR drive2	Name: neilsbed Description: 1121R-1*2P 2PIN P=3.96mm 90 degree single row PIN yellow	BAT2+SCR	positive battery SCR drive2
J8	positive battery SCR	Name: neilsbed	BAT3+SCR	positive battery

No.	Definition	Specification	Name	Description
	drive3	Description: 1121R-1*2P 2PIN P=3.96mm 90 degree single row PIN yellow		SCR drive3
J2	A phase bypass SCR1 drive	Name: neilsbed Description: 1121R-1*2P 2PIN P=3.96mm 90 degree single row PIN yellow	BPS_A_SCR1	A phase bypass SCR1 drive
J3	A phase bypass SCR2 drive	Name: neilsbed Description: 1121R-1*2P 2PIN P=3.96mm 90 degree single row PIN yellow	BPS_A_SCR2	A phase bypass SCR2 drive
J4	B phase bypass SCR1 drive	Name: neilsbed Description: 1121R-1*2P 2PIN P=3.96mm 90 degree single row PIN yellow	BPS_B_SCR1	B phase bypass SCR1 drive
J5	B phase bypass SCR2 drive	Name: neilsbed Description: 1121R-1*2P 2PIN P=3.96mm 90 degree single row PIN yellow	BPS_B_SCR2	B phase bypass SCR2 drive
J10	C phase bypass SCR drive1	Name: neilsbed Description: 1121R-1*2P 2PIN P=3.96mm 90 degree single row PIN yellow	BPS_C_SCR1	C phase bypass SCR1 drive
J20	C phase bypass SCR drive2	Name: neilsbed Description: 1121R-1*2P 2PIN P=3.96mm 90 degree single row PIN yellow	BPS_C_SCR2	C phase bypass SCR2 drive

### 5.3 PFC power board

Function overview:

- Boost circuit IGBT
- Charging circuit MOSFET
- Battery soft start resistor



Figure 14 PFC power board

Input and output interface definition

Table 6 PFC power board interface

No.	Definition	Specification	Name	Description
P6	Assistant power 15V+	Name: neilsbed Description: 1121S-1*2P 2PIN P=3.96mm 180° single row square PIN white	Assistant power	15V+

No.	Definition	Specification	Name	Description
P9	BUS+	Name: blade terminal Description: 4PIN 10A M4 screw hole straight leg T=0.8mm	BUS+	BUS+
P10	BUS-	Name: blade terminal Description: 4PIN 10A M4 screw hole straight leg T=0.8mm	BUS-	BUS-
P14	PFC/charger drive signal	301S-2*15P 30PIN P=2.54mm 180° two rows square PIN black horn		PFC/charger drive signal
P20	Assistant power 15V+	Name: neilsbed Description: 1121S-1*2P 2PIN P=3.96mm 180° single row square PIN white	Assistant power	15V+
P22	BAT+/BAT- battery cold start power	Name: neilsbed Description: 1121S-1*3P 3PIN P=3.96mm 180° single row square PIN white	BAT+/BAT-	battery cold start power
J18	BUS+/BUS- Voltage detection	Name: neilsbed Description: 1121S-1*3P 3PIN P=3.96mm 180° single row square PIN white	BUS+/BUS-	BUS+/BUS- Voltage detection
J25	BAT+/BAT- Voltage detection	Name: neilsbed Description: 1121S-1*3P 3PIN P=3.96mm 180° single row square PIN white	BAT+/BAT-	BAT+/BAT- Voltage detection

## 5.4 INV. Inductor board

Function overview:

- INV LC filter
- Output current detection
- Inv. inductor current detection



Figure 15 Inv. Inductor board (10K)



Figure 16 Inv. Inductor board (15-20K)

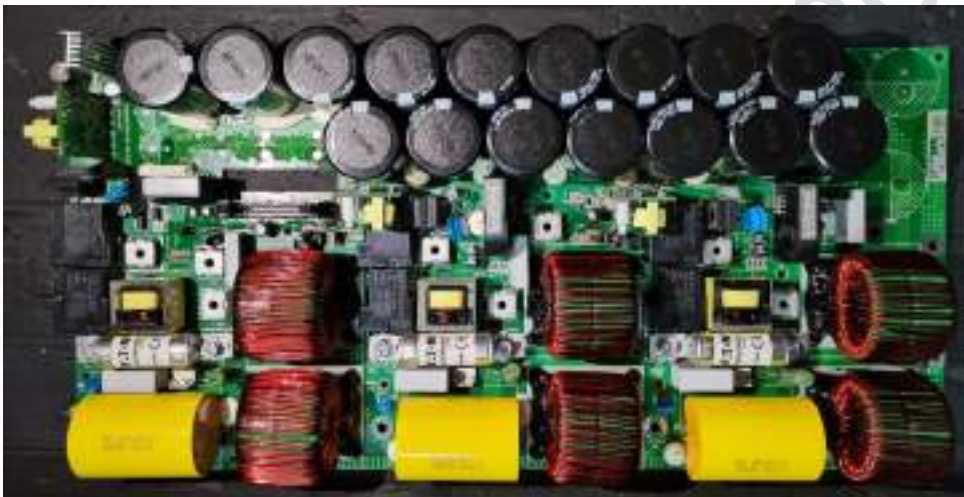

Figure 17 Inv. Inductor board (30K)



Figure 18 Inv. Inductor board (40K)

Input and output interface definition

Table 7 Inv. Inductor board interface

No.	Definition	Specification	Name	Description
-----	------------	---------------	------	-------------

No.	Definition	Specification	Name	Description
P2	VOUT_A Output A phase	Name: blade terminal Description: 4PIN 10A M4screw hole straight leg T0.8mm tinned copper	VOUT_A	Output A phase
P3	BPS_A Bypass A phase Output	Name: blade terminal Description: 4PIN 10A M4screw hole straight leg T0.8mm tinned copper	BPS_A	Bypass A phase Output
P5	BPS_B Bypass B phase Output	Name: blade terminal Description: 4PIN 10A M4screw hole straight leg T0.8mm tinned copper	BPS_B	Bypass B phase Output
P6	VOUT_B Output B phase	Name: blade terminal Description: 4PIN 10A M4screw hole straight leg T0.8mm tinned copper	VOUT_B	Output B phase
P8	BPS_C Bypass C phase Output	Name: blade terminal Description: 4PIN 10A M4screw hole straight leg T0.8mm tinned copper	BPS_C	Bypass C phase Output
P9	VOUT_C Output C phase	Name: blade terminal Description: 4PIN 10A M4screw hole straight leg T0.8mm tinned copper	VOUT_C	Output C phase
P12	N Neutral	Name: blade terminal Description: HIPOWER Cable Copper Block II Brass H65 T=1.5mm Foxed Tin	N	Neutral
P25	N Neutral	Name: blade terminal Description: HIPOWER Cable Copper Block II Brass H65 T=1.5mm Foxed Tin	N	Neutral
P29	N Neutral	Name: blade terminal Description: HIPOWER Cable Copper Block II Brass H65 T=1.5mm Foxed Tin	N	Neutral
P40	PH2_INV_FUSE-P2 B phase inv.fuse	Name: blade terminal Description: HIPOWER Cable Copper Block II Brass H65 T=1.5mm Foxed Tin	PH2_INV_FUSE- P2	B phase inv.fuse
P42	PH3_INV_FUSE-P2 C phase inv.fuse	Name: blade terminal Description: HIPOWER Cable Copper Block II Brass H65 T=1.5mm Foxed Tin	PH3_INV_FUSE- P2	C phase inv.fuse
P44	PH1_INV_FUSE-P2 A phase inv.fuse	Name: blade terminal Description: HIPOWER Cable Copper Block II Brass H65 T=1.5mm Foxed Tin	PH1_INV_FUSE- P2	A phase inv.fuse
J1	PH1_INV_Q_C1E2&VO UT_A A phase inv.DC component and Output voltage sampling	Name: neilsbed Description: 1121S-1*3P 3PIN P=3.96mm 180° single row square PIN white	PH1_INV_Q_C1 E2&VOUT_A	A phase inv.DC component and Output voltage sampling
J2	PH2_INV_Q_C1E2&VO UT_B	Name: neilsbed Description: 1121S-1*3P 3PIN P=3.96mm 180° single row	PH2_INV_Q_C1 E2&VOUT_B	B phase inv.DC component and

No.	Definition	Specification	Name	Description
	B phase inv.DC component and Output voltage sampling	square PIN white		Output voltage sampling
J3	PH3_INV_Q_C1E2&VO UT_C C phase inv.DC component and Output voltage sampling	Name: neilsbed Description: 1121S-1*3P 3PIN P=3.96mm 180° single row square PIN white	PH3_INV_Q_C1 E2&VOUT_C	C phase inv.DC component and Output voltage sampling
J4	INV SCR drive/output current detection signal	Name: neilsbed Description: 301S-2*13P 26PIN P=2.54mm 180° two rows square PIN black horn		INV SCR drive/output current detection signal

### 5.5 Inverter power board

Function overview:

- Auxiliary power
- Half-bridge inverter circuit
- Fan speed regulation circuit



Figure 19 Inverter power board

Input and output interface definition

Table 8 Inv. Power board interface

No.	Definition	Specification	Name	Description
P13	+15V/-15V ASSISTANT POWER	Name: neilsbed Description: 1121S-2P P=3.96mm 180 degree single row square PIN white	+15V/-15V	ASSISTANT POWER
P28	+24V_FAN Fan power	Name: neilsbed Description: 1121S-2P P=3.96mm 180 degree single row square PIN white	+24V_FAN	Fan power
J4	VBPS_A/BAT+/VINV_A Supply power from auxiliary power	Name: neilsbed Description: 1121S-2P P=3.96mm 180 degree single row square PIN white	VBPS_A/BAT+/V INV_A	Supply power from auxiliary power
J5	REC_THERMAL_SWITCH	Name: neilsbed	REC_THERMAL	REC temperature

No.	Definition	Specification	Name	Description
	REC temperature detection	Description: 2001S-2P P=2.54mm 180 degree single row square PIN white	_SWITCH	detection
J6	upper half bridge INV drive signal	Name: neilsbed Description: 301S-2*6P 12PIN P=2.54mm 180 ° 2PIN Black horn		upper half bridge INV drive signal
J7	ASSISTANT POWER +15V/-15V	Name: neilsbed Description: 1121s-1 *4P 4PIN P=3.96mm 180 degrees single row PIN yellow	ASSISTANT POWER	+15V/-15V
J8	ON Start up signal button	Name: neilsbed Description: 2001S-2P P=2.54mm 180 degree single row square PIN white	ON	Start up signal button
J9	REC_THERMAL_SWITCH REC temperature detection	Name: neilsbed Description: 2001S-2P P=2.54mm 180 degree single row square PIN white	REC_THERMAL_SWITCH	REC temperature detection
J10	lower half bridge INV drive signal	Name: neilsbed Description: 301S-2*5P 10PIN P=2.54mm 180 ° 2PIN Black horn		lower half bridge INV drive signal
J18	+24_CSU monitoring unit POWER	Name: neilsbed Description: 1121s-1 *2P 2PIN P=3.96mm 180 degree single row PIN white	+24_CSU	monitoring unit POWER

## 5.6 DSP board

Function overview:

- UPS control
- Communication circuit
- Parallel circuit
- Display circuit



Figure 20 DSP board

Input and output interface definition

Table 9 DSP board interface

No.	Definition	Specification	Name	Description
J7	ASSISTANT POWER +15V/-15V	Name: neilsbed Description: 1121s-1 *4P 4PIN P=3.96mm 180 degrees single row PIN yellow	ASSISTANT POWER	+15V/-15V

No.	Definition	Specification	Name	Description
J1	A phase INV voltage/output voltage sampling signal	Name: neilsbed Description: Hip3340-RM M17.PCB HPM3340	Vinv_A/Vout_A	A phase INV voltage/output voltage sampling signal
J2	B phase INV voltage/output voltage sampling signal	Name: neilsbed Description: Hip3340-RM M17.PCB HPM3340	Vinv_B/Vout_B	B phase INV voltage/output voltage sampling signal
J3	C phase INV voltage/output voltage sampling signal	Name: neilsbed Description: Hip3340-RM M17.PCB HPM3340	Vinv_C/Vout_C	C phase INV voltage/output voltage sampling signal
P20	Assistant power 15V+	Name: neilsbed Description: 1121S-2P P=3.96mm 180° single row square PIN white	Assistant power	15V+
J23	input voltage sampling	Name: neilsbed Description: HIP3340-RM M17.PCB HPM3340	Vin_A/Vin_N	input voltage sampling
J18	BUS voltage sampling	Name: neilsbed Description: HIP3340-RM M17.PCB HPM3340	Vbus+/Vbus-	BUS voltage sampling
J17	parallelsignal1	Name: neilsbed Description: 2001S-1*13P 13PIN P=2.54mm 180 ° square PIN white		parallelsignal1
J19	parallelsignal2	Name: neilsbed Description: 2001S-1*13P 13PIN P=2.54mm 180 ° square PIN white		parallelsignal2
J12	monitor& communication signal	Name: neilsbed Description: 201S-2*7P 14PIN P=2.54mm 180 degrees double row square PIN black		monitor& communication signal
CN3	LCD display signal	Name: neilsbed Description: 302NS-2*8P 16PIN P=2.54mm 180° two rows square PIN black		LCD display signal
P14	PFC drive signal	Name: neilsbed Description: 301S-2*15P 30PIN P=2.54mm 180° two rows square PIN black horn		PFC drive signal
P15	PFC inductor board relay/SCR drive signal	Name: neilsbed Description: 301S-2*5P 10PIN P=2.54mm 180° two rows square PIN black horn		PFC inductor board relay/SCR drive signal
J4	INV. inductor board INV. SCR drive/output current detection signal	Name: neilsbed Description: 301S-2*13P 26PIN P=2.54mm 180° two rows square PIN black horn		INV. inductor board INV. SCR drive/output current detection signal
J6	upper half bridge INV	Name: neilsbed		upper half bridge

No.	Definition	Specification	Name	Description
	drive signal	Description: 301S-2*6P 12PIN P=2.54mm 180° two rows square PIN black horn		INV drive signal
J10	lower half bridge INV drive signal	Name: neilsbed Description: 301S-2*5P 10PIN P=2.54mm 180° two rows square PIN black horn		lower half bridge INV drive signal

### 5.7 Adapter board

Function overview:

- Signal adapter function



Figure 21. adapter interface

Input and output interface definition

Table 10 adapter board interface

No.	Definition	Specification	Name	Description
J1	RS232/485_A signal	Name: neilsbed Description: 2001S-1*4P 4PIN P=2.54mm 180 degrees single row PIN white	RS232/485_A IN	RS232/485_A signal
J22	Module SNMP2 signal output	Name: neilsbed Description: 2001S-1*3P 3PIN P=2.54mm 180 degrees single row PIN white	SNMP2 OUT	SNMP2 signal
J28	SNMP1 signal	Name: neilsbed Description: 2001S-1*4P 4PIN P=2.54mm 180 degrees single row PIN white	SNMP1 IN	SNMP1 signal

### 5.8 RJ45 interface board

Function overview:

- signal interface function



Figure 22. RJ45 interface board interface

Input and output interface definition

*Table 11 RJ45 interface board interface*

No.	Definition	Specification	Name	Description
J3	RJ45_2 signal	Name: neilsbed Description: 2001R-1*5P 5PIN P=2.54mm 90 degree single row square PIN beige	RJ45_2	RJ45_2 signal
J4	RJ45_1 signal	Name: neilsbed Description: 2001R-1*5P 5PIN P=2.54mm 90 degree single row square PIN beige	RJ45_1	RJ45_1 signal
J1	RJ45_2 signal	Name: PC interface Description: RJ45 female seat 8PIN black 90 degree metal housing	RJ45_2	RJ45_2 signal
J2	RJ45_1 signal	Name: PC interface Description: RJ45 female seat 8PIN black 90 degree metal housing	RJ45_1	RJ45_1 signal

5.9 EPO interface board

Function overview:

- signal interface function

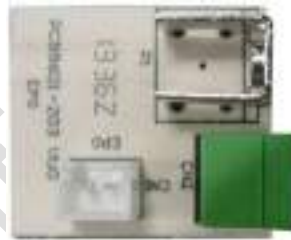

*Figure 23.EPO interface board interface*

Input and output interface definition

*Table 12 EPO interface board interface*

No.	Definition	Specification	Name	Description
CN1	EPO signal	Name: neilsbed Description: 2001S-1*2P 2PIN P=2.54mm 180 ° single row PIN white	EPO	EPO signal
CN2	EPO signal	Name: neilsbed Description: 2PIN P=3.81mm 90 degree single row square PIN green seat	EPO	EPO signal

5.10 USB interface board

Function overview:

- signal interface function



Figure 24 .USB interface board interface

Input and output interface definition

Table 13 USB interface board interface

No.	Definition	Specification	Name	Description
J1	RS232(USB) signal	Name: neilsbed Description: 2001S-1*4P 4PIN P=2.54mm 180 degrees single row PIN white	EPO	EPO signal
J9	Dry contact signal	Name: neilsbed Description: 2001S-1*4P 4PIN P=2.54mm 180 degrees single row PIN white	Dry Contact	Dry contact signal
USB	USB signal	Name: PC interface Description: USB interface seat mother seat 6PIN black square 90 degrees	USB	USB signal

### 5.11 parallel interface board

Function overview:

- External parallel signal interface function



Figure 25.parallel interface board interface

Input and output interface definition

Table 14 parallel interface board interface

No.	Definition	Specification	Name	Description
J5	Parallel signal	Name: neilsbed Description: 2001S-1*13P 13PIN P=2.54mm 180 degrees single row PIN white	Parallel signal	Parallel signal
J20	Parallel signal1	Name: PC interface Description: DB15 Male Seat P=2.29mm Black 90 ° Screw Separate with Serial Port	Parallel signal1	Parallel signal1

No.	Definition	Specification	Name	Description
J28	Parallel signal2	Name: PC interface Description: DB15 Male Seat P=2.29mm Black 90 ° Screw Separate with Serial Port	Parallel signal2	Parallel signal2

## 6 Inspection before installation

### 6.1 Room environment inspection

✓ UPS room:

UPS should be installed in a cool, dry, clean and well-ventilated environment, such as the room temperature should be < 40°C, the humidity ≤ 95% when 20°C, not obvious dust on the floor, especially without any conductive powder. The room air cannot contain acid mist or other conductive medium. For detail, please refer to the users' manual and other specifications.

✓ Battery room:

The battery should be also placed in a cool, dry, clean and well-ventilated environment. The available temperature is 15°C-25°C, typically is 20°C. The place where the battery located should keep the constant temperature and far away from heat and vents.

### 6.2 UPS location inspection

The users' manual offers the detailed installation instruction, it can be referred for installation.

- ✓ Check if enough space is left for maintenance operation, ensure that the operator can still pass through freely when the door is fully opened.
- ✓ There is no obstruction in the front, above and below of UPS. Enough space should be left for ventilation.
- ✓ Air is primarily comes from front door, so check if the front door leave enough air inlet space.

### 6.3 UPS visual inspection

◆ **Particularly important: it is necessary to have a comprehensive inspection of internal and external of UPS**

1. Check the external power cable connection(include input /Output phase sequence battery polarity, fasten bolt and ect.)
2. Check if the parallel cables are connected well? If they are routed separately from power cables?
3. Check if the external signal of the battery box and LBS (when needed) connections are good or correct?
4. Check if the internal signal cable is connected well, if the cable is loosed by shaking it gently
5. Check if the internal boards or components are disconnected or damaged?

### 6.4 External cables and switch capacity inspection

- ✓ For power cable selection and connection method, please refer to the user manual and related specification.
- ✓ Check if the breakers rated capacity of UPS input, Output and distribution cabinet are appropriate.
- ✓ Pay attention to the Neutral and Ground protection inspection:
  - If the Neutral and Ground cable size meets the requirement?**
  - Neutral has separate input and output, connect to the same Neutral is not allowed.**
  - Check and confirm all the cabinets and cable ducts have been grounded according to the local provisions.**
- ✓ If the bypass has different power source, please check if the short copper-bar of the internal mains and bypass has been removed, do the connection correctly according to the users' manual.
- ✓ If the battery breaker box is provided, check if the connection of it is correct.
- ✓ Check if the UPS input/output wiring is reasonable and the cable is not in contact with any sharp edges of objects.
- ✓ If the user install the remote contact to realize the EPO function, make sure that the EPO cable is not interference by other main power signals to avoid UPS malfunction. About how to realize the EPO function by remote contact, please refer to user's manual.
- ✓ About other control cables connection, please refer to the relevant chapters of the user's manual.

### 6.5 External auto switching and generator power distribution inspection

- ✓ Confirm that the ATS at the input side is three level switch, that is the Neutral cannot be cut off; if it is four level, confirm that when transfer between two sources, neutral should meet on-before-off principle.
- ✓ If the AC and generator can be selected at the input side, please confirm the proper connection between Neutral and Ground according to the relevant specifications.
- ✓ If the generator has dry contact, it is necessary to connect it to the generator dry contact of the monitor board.

### 6.6 Battery inspection

#### **The important security guidance when operating battery:**

- 1) Battery exists danger of short-circuit and possibly causes burning due to the short-circuit current.
- 2) The voltage may reach 240VDC when battery connected in series, which has deadly danger. So keep in mind to prevent electric shock.
- 3) The installation and operation of the battery must be carried out by professionals.
- 4) Note of eye protection to avoid accidental arc damage.
- 5) Remove all rings, watches, necklaces, bracelets and other metal objects.
- 6) The tools must be used with insulated handles.
- 7) Wear rubber gloves and protective aprons when do the battery operation.
- 8) If the battery has liquid leakage or housing damaged, place it in the ant-acid container and

deal it according to the local regulations.

- 9) If the electrolyte touches your skin, immediately wash it with a plenty of water.
- 10) The battery must be handled with reference to local environmental regulations.

**Focus on the following aspects:**

- 1) If the battery surface is clean, the appearance is damaged, deformed and leakage;
- 2) Check if the connection among battery is reliable, if the screws are tightened, if there is corrosion and confirm that all battery terminals are coated with insulating material;
- 3) Check if there at least 10mm interval between the vertical side of the battery to ensure the free flow of the air around the battery;
- 4) At least 150mm space should be left between battery top and upper frame for monitoring and maintenance of the battery;
- 5) Check if the battery cabinet or battery rack installed reliably, if there is good grounded. One cable must be individually connected between battery breaker box and UPS;
- 6) About connections between battery pack and UPS, battery and battery, battery pack and battery pack and rated capacity of breaker, please refer to the user's manual and relevant specifications;
- 7) Check if the wiring is reasonable and the cable is not in contact with any sharp edges of objects;
- 8) If the battery cabinet is installed on a raised floor, the battery power cable and breaker controlled cable can route through the floor; if the battery cabinets are side-by-side and installed on a solid floor, cables can go into the outlet holes at the bottom of the cabinet side to connect the battery cabinets;
- 9) Check and confirm that the cables are correctly and safely connected to the battery terminal blocks of the UPS. Don't reverse the battery. About the terminal block diagram, please refer to the user's manual.
- 10) Make sure that the battery breaker box is switched off.

## 7 UPS maintenance

### 7.1 Guidelines for good service

1.1 The UPS is almost maintenance-free and is designed to have a failure rate less than 1% a year.

Periodical service is only needed for the fans; the UPS has a low heat generation.

A battery change after 3-6 years can be expected and, apart from the service to the fan, it should normally be the only service done to the unit.

1.2 Due to the size of the UPS and the highly complex of the PCB, board level repair is not recommended, take the following measures instead:

Improve the reliability of the design;

Replace the PCBA;

## 7.2 Security conditions

Warning: When the UPS is operating, all the electronic parts connected directly to the power supply and all internal components including the battery exist high voltage. Even disconnected from the power supply, all internal parts including the battery still have dangerous voltage (except the communication output) .

2.1 Only authorized professionals with relevant knowledge can open the machine, the others cannot open it for maintenance.

For authorized service personnel:

Do not work alone, a second person should be standing by to assist and render help in case of accident.

Danger may occur only during the installation and maintenance. Any person operating in a normal manner is safe.

2.2 If the UPS is in need of repair, the process A operation is recommended(This is completely safe) : Disconnect all input power supply and battery. Load is allowed to turn off for process A. The specific steps can be seen in chapter 3.

If the load is not allowed to turn off, please enter the maintenance bypass mode for maintenance. Follow the process B (refer to chapter III for specific information) . Please note that the do the maintenance in maintenance bypass mode is not absolutely safe, Part of circuits are still at work.

In maintenance mode, the load is directly connected to the power via the bypass, so the UPS will not provide any protection.

2.3 To avoid electrostatic discharge damage, ensure that the maintenance is under the ESD safe conditions

- work on an anti-static mat;
- ground yourself and the unit when it is opened.

2.4 Be careful when disconnect the battery:

- Do not wear metal bracelets and etc.
- do not short circuit the batteries

2.5 If the UPS must be repaired during the operation such as measurement, Make sure that the power supply is isolated. In this case, a transformer can be used between the UPS and power.

Before maintenance, this manual should be entirely read.

## 7.3 Shutdown-disassembly/reassembly UPS

Warning: when UPS works, a large amount of energy is stored in the internal BUS capacitor, no electricity cannot be guaranteed inside the UPS with mains isolation, so it needs extra attention when maintenance. Disconnect all external input power of the fault machine for maintenance, After opening the case, use the bleed resistor to release the energy stored in BUS capacitor to avoid injury to person.

3.1 Please refer to the user's manual on UPS installation content;

3.2 First read chapter 2 "Security conditions"

3.3 If the UPS is in need of repair, the process A operation is recommended (This is completely safe) : Disconnect all input power supply and battery. Load is allowed to turn off for process A. The specific steps can be seen in chapter 3.

If the load is not allowed to turn off, please enter the maintenance bypass mode for maintenance. Follow the process B (refer to chapter III for specific information) . Please note that the do the maintenance in maintenance bypass mode is not absolutely safe, Part of circuits are still at work.

In maintenance mode, the load is directly connected to the power via the bypass, so the UPS will not provide any protection.

Step A: the load may be closed

A1 Turn off the load, disconnect all input power supply and battery;

A2 Make input/output/battery air-switch on "OFF" state

A3 Remove the right panel, left panel and top cover, do the maintenance

A4 Install the right and left panel, top cover

A5 Tighten the four screws;

A6 Connect the mains/battery/load, switch on the battery switch, press the start key to start the unit

A7 If UPS has no fault, it will has output when output switch is switched on.

A8 Switch-on the input switch, the UPS will transfer to mains, and charge the battery.

A9 Close the front door.

Step B: The load may not be closed.

B1 remove the maintenance screws and baffles to check whether the machine enter the maintenance bypass mode

B2 If the UPS goes to the maintenance bypass mode, switch on the maintenance bypass switch, otherwise do the maintenance in accordance with the process A;

B3 Remove the right panel, left panel and top cover, do the maintenance

B4 Install the right, left panels and top cover

B5 Switch on the input/output switch, the UPS enter the maintenance bypass mode

B6 Switch off the maintenance switch, install baffles and screws, the unit goes to the bypass mode;

B7 If both the mains and battery are normal, the unit goes into the line mode and charging after a period of time;

## 7.4 Troubleshooting

This chapter provides information that can help you to locate faults in YDC3300 UPS.

Some data may have to be measured to fix the fault. If it needs to be measured during the operation, the device should be isolated from the mains. In this case, a transformer can be used between device and the power. It also applies to the bypass input.

*Warning: when UPS works, a large amount of energy is stored in the internal BUS capacitor, it cannot be guaranteed that there is no electricity inside the UPS with mains isolation, so it needs extra attention when maintenance. Disconnect all external input power of the fault machine for maintenance. After opening the case, use the bleed resistor to release the energy stored in BUS capacitor to avoid injury to person.*

Before maintenance, please confirm the related reliable cable connection.

For the UPS fault, please record the software version and PCB version correctly.

#### **Warning s and precautions:**

*When fault occurs, make a note of the display (refer to code table) as the reference for maintenance.*

*Note: the UPS mains input switch cannot be OFF arbitrarily to avoid electricity interruption.*

#### **Fault analysis:**

Record the status of display, then fix the reason in accordance with the following questions.

1. if the input supply is abnormal? (over/under voltage)
2. If load changes? ( capacity or type)
3. If fire?
4. If smelly odor?
5. If abnormal noise?
6. If bad environment?(dust or moisture)
7. High temperature of UPS or ambient environment?

#### **Troubleshooting**

##### **Failure view:**

Please ensure the safe conditions before starting the maintenance. Please read chapter 2 “Security conditions” and chapter 3 “shutdown-disassembly/reassembly UPS”;

After remove the case, checking the following items:

1. If the CONNECTOR or terminals loose?
2. If the transformer or other parts burst or discoloration especially the power components on the heat sink?
3. Is capacitor rupture or leak?
4. If any parts serious blow up especially power components on heat sink?

##### **Solutions:**

1. If the unit fails, due to higher probability damage of the INV-POWER board, replace the power board is ok.
2. If any power component on the power board is founded to blow up, replace it

according to the “replace PCB”;

3. If fan doesn't work with mains input, confirm that if the auxiliary power of the INV-POWER board is damaged and needs to be replaced
4. Charger shows abnormal, check if the charging circuit in the PFC power board is damaged and need to be replaced.

4.1The display has no light and response when connected mains

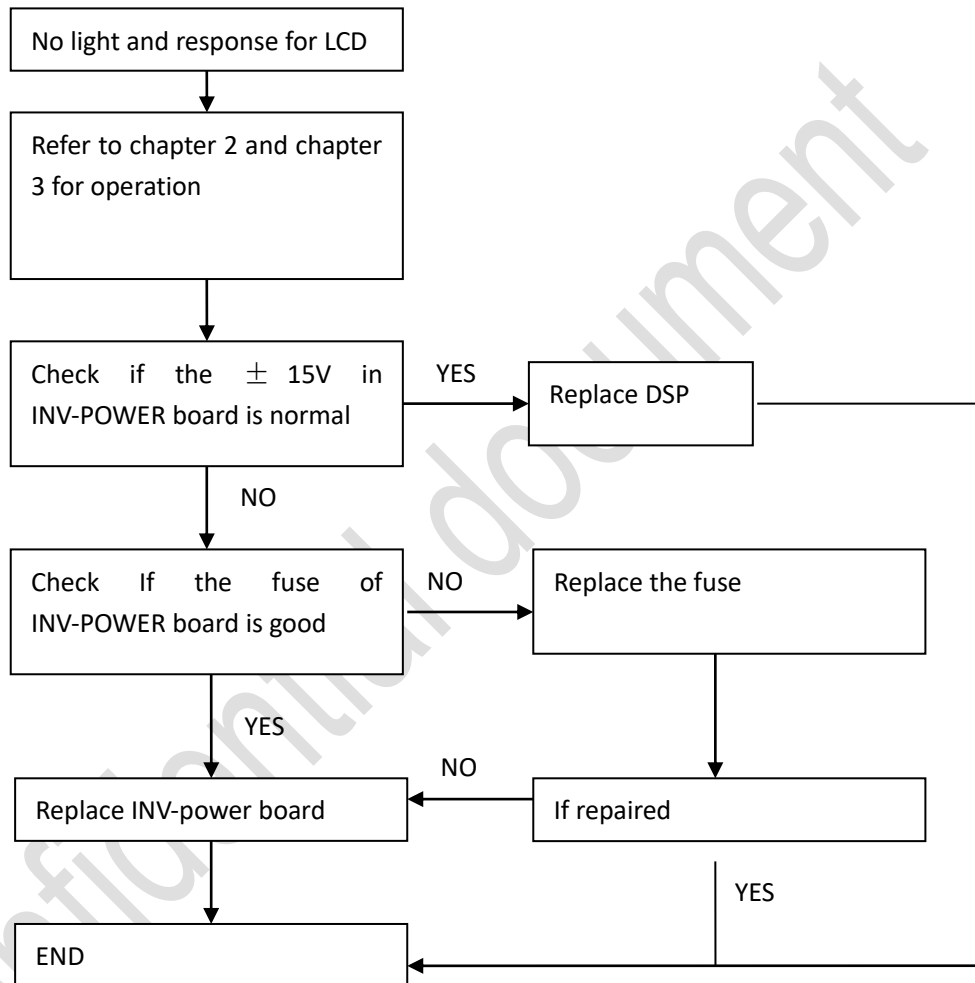

4.2 Common fault troubleshooting

Table 15 Common fault troubleshooting

LCD display fault code	UPS alarm	Buzz	LED	The board may be damaged(1 shows the max. Probability, 2 shows the less probability)		
				1	2	3
1	Rectifier fault	long beep	Fault ON	PFC power board	PFC inductor board	control detection board
2	Inv. fault(include Inv. Bridge arm )	long beep	Fault ON	INV power board	INV inductor board	control detection

						board
3	Inv. SCR short	long beep	Fault ON	INV inductor board	control detection board	
4	Inv. SCR break	long beep	Fault ON	INV inductor board	control detection board	
5	Bypass SCR short	long beep	Fault ON	PFC inductor board	control detection board	
6	Bypass SCR break	long beep	Fault ON	PFC inductor board	control detection board	
7	Fuse broken	long beep	Fault ON	INV inductor board		
8	Paralle Relay fault	long beep	Fault ON	control detection board		
9	Fan fault	long beep	Fault ON	fan	INV power board	
10	Reserve	long beep	Fault ON			
11	Auxiliary power fault	long beep	Fault ON	INV power board	control detection board	
12	Power initialization fault	long beep	Fault ON	control detection board		
13	Positive battery Charge fault	long beep	Fault ON	PFC power board	PFC inductor board	control detection board
14	Negative battery Charge fault	long beep	Fault ON	PFC power board	PFC inductor board	control detection board
15	Bus over-voltage	long beep	Fault ON	PFC power board	PFC inductor board	control detection board
16	Bus under-voltage	long beep	Fault ON	PFC power board	PFC inductor board	control detection board
17	Large difference between $\pm$ Bus	long beep	Fault ON	PFC power board	PFC inductor board	control detection board
18	Soft start fail	long beep	Fault ON	PFC power board	PFC inductor board	control detection board

19	Rectifier over-temperature	twice/s	Fault ON	PFC power board	fan	
20	Inv. Over-temperature	twice/s	Fault ON	INV power board	fan	
21	Reserve	twice/s	Fault ON			
22	Battery reverse	twice/s	Fault ON	connection wrong	control detection board	
23	Parallel connection fault	twice/s	Fault ON	Parallel cable not connected well	control detection board	
24	CAN communication fault	twice/s	Fault ON	Setting parallel mode but only single UPS working	control detection board	
25	Share current when parallel fault	twice/s	Fault ON	Parallel cable problem	control detection board	
26	Battery high voltage	once/s	Fault flash	battery fault	PFC power board	control detection board
27	Input phase sequence reverse	once/s	Fault flash	connection wrong		
28	Bypass reverse	once/s	Fault flash	connection wrong		
29	Output short circuit	once/s	Fault flash	output short		
30	Rectifier over-current	once/s	Fault flash	PFC power board	control detection board	
31	Bypass over-current	once/s	BPS flash	bypass output overload		
32	Over load	once/s	INV or BPS flash	output overload		
33	No battery	once/s	BATTERY flash	battery disconnected	battery voltage abnormal	
34	Battery voltage low	once/s	BATTERY flash	Low battery and shutdown		
35	Low battery pre-alarm	once/s	BATTERY flash	Battery low and pre-alarm		
36	Internal communication error	once/2s	Fault flash	control detection board		
37	Inv. DC excessive	once/2s	INV flash	INV inductor board	control detection board	

38	Overload in parallel	once/2s	INV flash	output overload	Redundancy number setting is improper	control detection board
39	Mains voltage abnormal	once/2s	BATTERY ON	Input voltage abnormal		
40	Mains frequency abnormal	once/2s	BATTERY ON	Input frequency abnormal		
41	Bypass ultra protection		BPS flash	bypass abnormal		
42	Bypass ultra tracking		BPS flash	bypass abnormal		
43	Start invalid			Inverter cannot be started due to some faults		
44	Reserve					
45	Inverter not on			The inverter not start after 2min without any alarm		
46	Output switch not ON	Once per 3s		Detect output switch	Output signal in the detection board is wrong	

**8 Battery replacement**

1. Refer to the user’s manual for battery installation operation;
2. Ensure the safe conditions before any operation. Please read chapter 2 “Security conditions” and chapter 3 “shutdown-disassembly/reassembly UPS” carefully. Be careful when disconnecting the battery. Short circuit will damage the battery or wiring.

**Note:**

The battery with the same brand/type/date of manufacture is recommended to ensure a long battery life. The voltage difference among the batteries should not more than ±150 mV.

We recommended to measure the voltage of each battery during discharge to ensure the voltage differences no more than ±150mV. The battery pack capacity will be affected if there is one or more battery voltages differ too much. In the worst case, it will damage the other battery.

The voltage difference should be reduced after a long period of charging.

**8.1 YDC3300 standard battery string:**

1. Switch of the battery switch (if have), remove the battery baffle;
2. Remove the battery, and use the new battery
3. Carefully checked if all the connection is good
4. Re-install the battery drawer;

5. Measure the total voltage of the battery;
6. Install all screws, baffles, switch on the battery switch (if have).

**8.2 Single Battery cabinet:**

1. Close the battery switch (if have)
2. Disconnect the connection between the UPS and the battery cabinet;
3. Replace the battery according to the battery cabinet user's manual;
4. Thoroughly check if all the connections are correct;
5. Measure the total voltage of the battery;
6. Open the battery switch (if have)

**9 PCB replacement**

*Warning: when UPS works, a large amount of energy is stored in the internal BUS capacitor, it cannot be guaranteed that there is no electricity inside the UPS with mains isolation, so it needs extra attention when maintenance. Disconnect all external input power of the fault machine for maintenance. After opening the case, use the bleed resistor to release the energy stored in BUS capacitor to avoid injury to person.*

**General instruction**

The internal voltage of the UPS is high enough to cause serious personal injury or death.

1. Ensure the safe conditions before any operation. Please read chapter 2 "Security conditions" and chapter 3 "shutdown-disassembly/reassembly UPS" carefully. Be careful when disconnecting the battery. Short circuit will damage the battery or wiring.
2. ESD(electrostatic discharge) precautions: The PCB is very sensitive to electrostatic. When pick and place the board, ensure that the operating personnel and equipment are grounded well.  
The new board is taken out from the anti-static packaging only when necessary, the old board removed from the UPS should be immediately placed in anti-static packaging.
3. Shut down the UPS according to the process A or B in chapter 3.
4. When disconnect any connectors, hold the male while pulling the female (sometimes need to press the connector snaps), otherwise, it will make the connector or PCB bending.  
Mark it before disconnecting in order to facilitate the re-assembly connector.
5. Ensure the compatibility between the new board and old board before replacement.
6. When re-install the connector, the male and female should be aligned, or the PCB or UPS will be damaged.
7. Confirm if the connection is correct after replacing PCB.

**Input EMI board replacement**

1. Ensure the safe conditions before any operation. Please read chapter 2 "Security conditions" and chapter 3 "shutdown-disassembly/reassembly UPS" carefully.

2. Operate according to the steps 1-3 of process A or steps 1-3 of process B in chapter 3;
3. Remove the screws of left panel of UPS, remove the cover, use the bleeder resistor to release the energy stored in the Bus capacitor;
4. Remove all the cables of the EMI board;
5. Remove all the screws of the EMI board;
6. Replace the PCB, package the old PCB;
7. Install the screws and cables;
8. install the right panel and screws ;
9. Continue with the steps 4-9 in process A or 4-8 in process B in chapter 3;

**Replace DSP board**

1. Ensure the safe conditions before any operation. Please read chapter 2 “Security conditions” and chapter 3 “shutdown-disassembly/reassembly UPS” carefully.
2. Operate according to the steps 1-3 of process A or steps 1-3 of process B in chapter 3;
3. Remove the screws of left panel of UPS, remove the cover, use the bleeder resistor to release the energy stored in the Bus capacitor;
4. Remove all the cables of the DSP board;
5. Remove all the screws of the DSP board;
6. Replace the PCB, package the old PCB;
7. Install the screws and cables;
8. install the right panel and screws;
9. Continue with the steps 4-9 in process A or 4-8 in process B in chapter 3;

**Replace PFC inductor board**

1. Ensure the safe conditions before any operation. Please read chapter 2 “Security conditions” and chapter 3 “shutdown-disassembly/reassembly UPS” carefully.
2. Operate according to the steps 1-3 of process A or steps 1-3 of process B in chapter 3;
3. Remove the screws of left panel of UPS, remove the cover, use the bleeder resistor to release the energy stored in the Bus capacitor;
4. Remove all the cables of the PFC inductor board;
5. Remove all the nuts and screws of the PFC inductor board;
6. Replace the PCB, package the old PCB;
7. Install the nuts, screws and cables;
8. install the left panel and screws;
9. Continue with the steps 4-9 in process A or 4-8 in process B in chapter 3;

**Replace PFC power board**

1. Ensure the safe conditions before any operation. Please read chapter 2 “Security conditions” and chapter 3 “shutdown-disassembly/reassembly UPS” carefully.
2. Operate according to the steps 1-3 of process A or steps 1-3 of process B in chapter

- 3;
3. Remove the screws of left panel of UPS, remove the cover, use the bleeder resistor to release the energy stored in the Bus capacitor;
4. Remove all the cables of the PFC power board
5. Remove all the screws of the PFC power board;
6. Replace the PCB, package the old PCB;
7. Install the screws and cables;
8. install the right panel and screws;
9. Continue with the steps 4-9 in process A or 4-8 in process B in chapter 3;

**Replace INV inductor board**

1. Ensure the safe conditions before any operation. Please read chapter 2 “Security conditions” and chapter 3 “shutdown-disassembly/reassembly UPS” carefully.
2. Operate according to the steps 1-3 of process A or steps 1-3 of process B in chapter 3;
3. Remove the screws of left panel of UPS, remove the cover, use the bleeder resistor to release the energy stored in the Bus capacitor;
4. Remove all the cables of the INV inductor board
5. Remove all the screws and nuts of the INV inductor board;
6. Replace the PCB, package the old PCB;
7. Install the nuts, screws and cables;
8. install the left panel and screws;
9. Continue with the steps 4-9 in process A or 4-8 in process B in chapter 3;

**Replace INV power board**

1. Ensure the safe conditions before any operation. Please read chapter 2 “Security conditions” and chapter 3 “shutdown-disassembly/reassembly UPS” carefully.
2. Operate according to the steps 1-3 of process A or steps 1-3 of process B in chapter 3;
3. Remove the screws of left panel of UPS, remove the cover, use the bleeder resistor to release the energy stored in the Bus capacitor;
4. Remove all the cables of the INV-POWER board
5. Remove all the screws of the INV power board;
6. Replace the PCB, package the old PCB;
7. Install the screws and cables;
8. install the right panel and screws;
9. Continue with the steps 4-9 in process A or 4-8 in process B in chapter 3;

**LCD on front panel**

1. Ensure the safe conditions before any operation. Please read chapter 2 “Security conditions” and chapter 3 “shutdown-disassembly/reassembly UPS” carefully.
2. Operate according to the steps 1-3 of process A or steps 1-3 of process B in chapter 3;

3. Open the front panel, remove 4pcs of nuts of the rear panel and then remove the rear panel;
4. Remove all the cables of the PCB
5. Remove all the screws of the PCB;
6. Replace the PCB, package the old PCB;
7. Install the screws and cables;
8. Install the rear panel and nuts;
9. Continue with the steps 4-9 in process A or 4-8 in process B in chapter 3;

## 10 Replace fan

Four fans are provided

1. Ensure the safe conditions before any operation. Please read chapter 2 “Security conditions” and chapter 3 “shutdown-disassembly/reassembly UPS” carefully.
2. Operate according to the steps 1-3 of process A or steps 1-3 of process B in chapter 3;
3. Remove the screws of right and left panels, remove the cover, use the bleeder resistor to release the energy stored in the Bus capacitor;
4. Remove the fan cables of the INV power board;
5. Remove all the screws of the fan;
6. Replace with a new fan;
7. Install the screws and cables;
8. Install right and left panels, and the screws;
9. Continue with the steps 4-9 in process A or 4-8 in process B in chapter 3;

## 11 PCB static maintenance

PFC inductor board

NO.	Description <sup>1</sup>	Type	Checked components	Detect Pin	Meter stall	Normal	abnormal
1	AC rectify	Diode	D1,D3,D6,D11,D14,D16	A/K	diode	0.36V	open or short
2	mains input	Relay	K1,K2,K6	4/5	Ω	open	short
3	Battery input	SCR	D7,D9,D18,D19,D20,D21	A/K	Ω	open	Short
4	Battery input	SCR	D7,D9,D18,D19,D20,D21	G/K	Ω	≈10Ω	open or short
5	Charge	SCR	Q70, Q71	A/K	Ω	open	Short
6	Charge	SCR	QJ1,QJ4,QJ5,QJ6, QJ7,QJ8,QJ3,QJ12	G/K	Ω	≈10Ω	open or short
7	Bypass	SCR	QJ1,QJ4,QJ5,QJ6, QJ7,QJ8,QJ3,QJ12	A/K	Ω	open	Short
8	Bypass	SCR	K7,K8,K9	G/K	Ω	≈10Ω	open or short
9	Bypass	Relay	K3, K4, K5	1/3	Ω	open	short

PFC power board

NO.	Description <sup>2</sup>	Type	Checked components	Detect Pin	Meter stall	Normal	abnormal
1	BOOST	Diode	D7-D12	A/K	diode	0.36V	open or short

2	BOOST	IGBT	Q1-12	E->C	diode	≈0.4V	open or short
3	BOOST	IGBT	Q1-12	G/E	Ω	≈10KΩ	open or short
4	Charge	FUSE	F3-4		Ω	0Ω	open
5	Charge	MOSFET	Q13-14	S->D	diode	≈0.46V	open or short
6	Charge	MOSFET	Q13-14	G/S	Ω	≈20KΩ	open or short

**INV inductor board**

NO.	Description <sup>3</sup>	Type	Checked components	Detect Pin	Meter stall	Normal	abnormal
1	INV	FUSE	F1-3		Ω	0Ω	open
2	INV	SCR	SCR1-6	A/K	Ω	Open	Short
3	INV	SCR	SCR1-6	G/K	Ω	20~40Ω	open or short
4	INV	Relay	RLY1-3	1/3	Ω	open	short

**INV power board**

NO.	Description <sup>4</sup>	Type	Checked components	Detect Pin	Meter stall	Normal	abnormal
1	INV	IGBT	Q1-12	E->C	diode	≈0.4V	open or short
2	INV	IGBT	Q1-12	G/E	Ω	≈10KΩ	open or short
3	Auxiliary power	FUSE	F1		Ω	0Ω	open
4	Auxiliary power	MOSFET	Q14-15	S->D	diode	≈0.46V	open or short
5	Auxiliary power	MOSFET	Q14-15	G/S	Ω	≈10KΩ	open or short

## 12 Stand-alone commissioning

Warning: When UPS is working, the internal Bus capacitor stores a lot of energy. But isolated with mains cannot guarantee completely no electricity inside the UPS and need extra attention when do the maintenance. When cut off all the external input power supplied for maintenance, use the bleed resistor to release the energy stored in Bus capacitor after open the case firstly to avoid causing injury to persons.

Please refer to the “UPS repair/maintenance”, especially the “Security maintenance conditions” and “Close-Disassembly/Reassembly UPS”.

The stand-alone commissioning requires intact UPS.

### 12.1 Startup steps

- 1) Before startup, confirm that the input/output connection is correct; measure the positive and negative battery voltage, battery breaker is temporarily open.
- 2) Close the UPS Output switch.
- 3) Close the UPS input switch. Close external input mains and start UPS by AC.
- 4) After AC start, check the LCD menu, working mode, matching ID number, the VA of UPS, output voltage level and the frequency is the same with the actual values.( refer to the following pictures). If not the same, immediately disconnect the mains to check or call the customer service hotline.



Figure 21 YDC3300 settings

- 5) Close the external battery breaker, check if the charge current on the LCD is normal
- 6) Simulate mains power failure test: Disconnect external main input breaker and check if the UPS can transfer to battery inv. Mode and the output is uninterrupted. Then close the external mains breaker to confirm the UPS enter the line mode. At last, check if the charge and output are normal.

## 12.2 Shutdown steps:

- 1) Switch on the output breaker
- 2) Press the OFF button the LCD panel and keep it for no less than 2s, UPS Inv. LED is off
- 3) Switch on the battery breaker
- 4) Switch on the input breaker and UPS shutdown
- 5) To completely isolate the AC power supply, the external grid input switch should be open. The main input distribution board is usually away from the UPS. It is necessary to inform the service personnel that the UPS is in repair by posting a label on it.

## 12.3 Emergency shutdown instructions

The EPO is designed as remote dry contact. When it needs to shutdown in emergency condition, press the key button for more than 3s, it will shut down.

## 12.4 Parameters setting

The setting function is controlled by 3 buttons (Enter ◡, Off ▲, On ▼): Enter ◡---goes into the setting page and value adjustment; Off ▲ & On ▼---for choosing different pages.

After the UPS turn ON, press buttons ◡ & ▲ for 2seconds and then goes into the setting interface page.

Note: Figurate left corner is the page number of the setting pages.

- 1) Mode setting

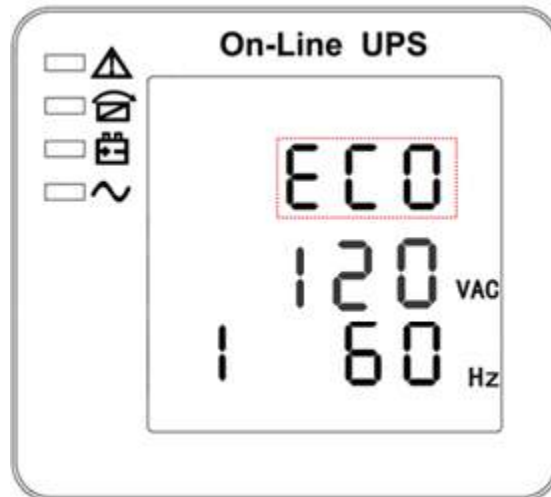

Mode setting (Note: Inside the broken-line is the flashing part.)

After entering the setting menu, its mode setting defaulted, and the mode setting line flashes as in above picture. ①Use button "⏏" to choose different mode. There are 3 different modes for setting: ECO, PAL, NOR. ②Press "ON" to exit the mode setting and save the mode setting value, and goes to output voltage setting. ③Press "OFF" to exit the mode setting, and goes to parallel redundancy quantity setting.

2)

Output voltage setting

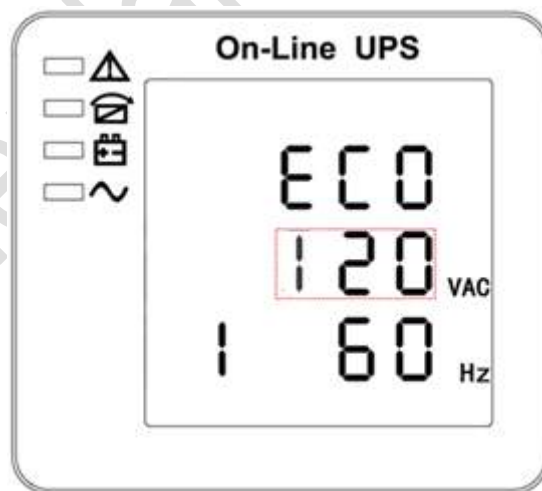

Output voltage setting (Note: Inside the broken-line is the flashing part.)

In the mode setting press "ON" or in frequency setting press "Off", it goes to the output voltage setting. The output voltage line flashes as in above picture. ①Use button "⏏" to choose the different output voltage. There are 3 different voltages---120, 127. ②Press "ON" to exit the output voltage setting and save the output voltage setting value, and goes to frequency setting. ③Press "OFF" to exit the output voltage setting, and goes to mode setting.



CAUTION!

When powered by inverter, it is necessary to turn off the inverter before setting voltage and frequency level.

3) Frequency setting

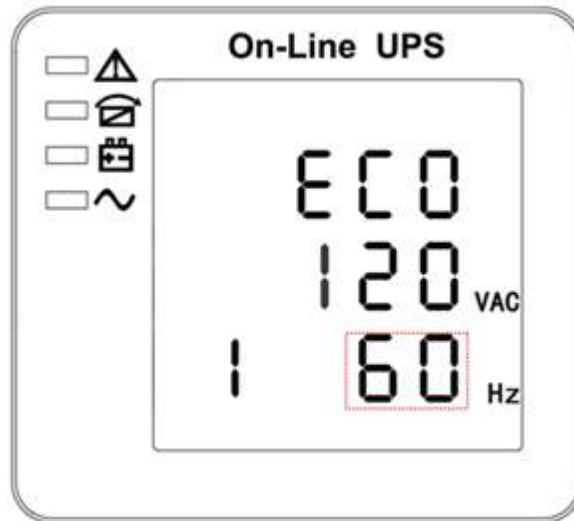

Frequency setting (Note: Inside the broken-line is the flashing part.)

In the output voltage setting press "ON" or in battery capacity setting press "OFF", it goes to the frequency setting. The frequency line flashes as in above picture. ①Use button "U" to choose the different frequency. There are 2 different frequency---50,60Hz. ②Press "ON" to exit the frequency setting and save the frequency setting value and goes to battery capacity setting. ③Press "OFF" to exit the frequency setting, and goes to output voltage setting.



**CAUTION!**

When powered by inverter, it is necessary to turn off the inverter before setting voltage and frequency level.

4) Battery capacity setting

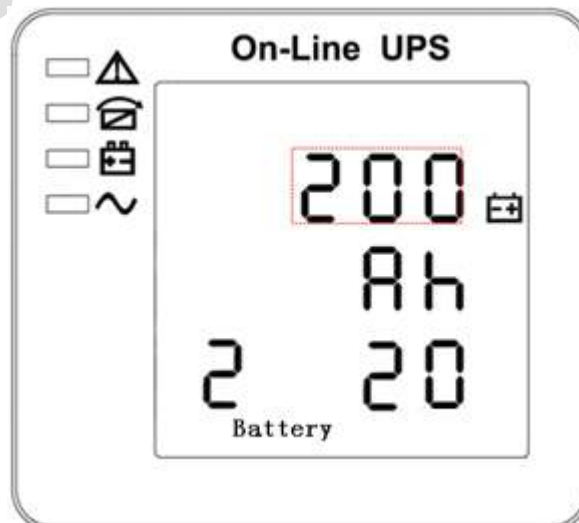

Battery capacity setting (Note: Inside the broken-line is the flashing part.)

In the frequency setting press “ON” or in battery quantity setting press “OFF”, it goes to the battery capacity setting. The battery capacity line flashes as in above picture. ①Use button “ $\cup$ ” to choose the different battery capacity. Battery capacity range is 1-999Ah. (Note: long-press of “ $\cup$ ” can adjustment battery capacity quickly.) ②Press “ON” to exit the battery capacity setting and save the capacity setting value and goes to battery quantity setting. ③Press “OFF” to exit the battery capacity setting and goes to frequency setting.

5) Bypass voltage upper limit setting

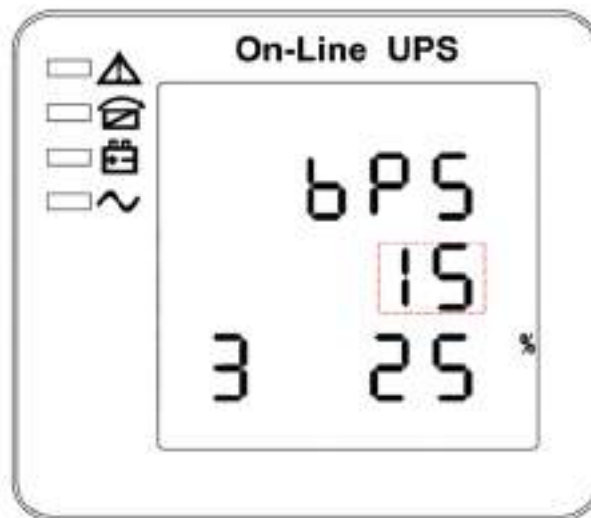

Bypass voltage upper limit setting (Note: Inside the broken-line is the flashing part.)

In the battery capacity setting press “ON” or in bypass voltage lower setting press “OFF”, it goes to the bypass upper limit setting. The bypass upper limit line flashes as in above picture. ①Use button “ $\cup$ ” to set the different bypass voltage upper limit. The bypass voltage upper limit range is 10%, 15%, 20%, 25 % (25% only for 120V output). ②Press “ON” to exit the bypass voltage upper limit setting and save the bypass voltage upper limit setting value and goes to bypass voltage lower limit setting. ③Press “OFF” to exit the bypass voltage upper limit setting and goes to battery capacity setting.

6) Bypass voltage lower limit setting

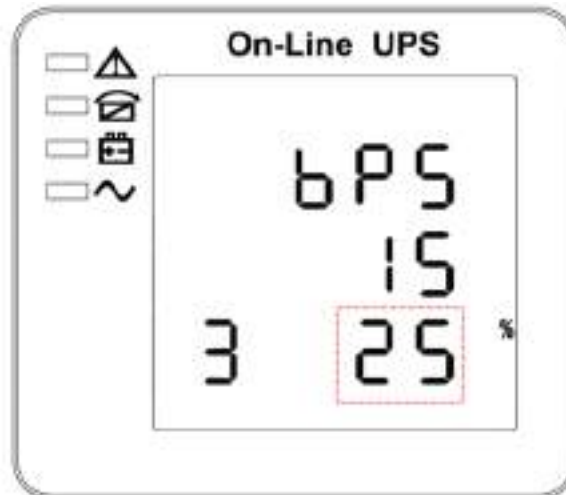

Bypass voltage lower limit setting (Note: Inside the broken-line is the flashing part.)

In the bypass voltage upper limit setting press “ON” or in parallel ID setting press “OFF”, it goes to the bypass lower limit setting. The bypass lower limit line flashes as in above picture. (“-” for negative, positive does not have any symbol.) ①Use button “↶” to set the different bypass voltage lower limit. The bypass voltage lower limit range is 10%, 20%, 30%, 40%. ②Press “ON” to exit the bypass voltage lower limit setting and save the bypass voltage lower limit setting value and goes to buzzer mute setting. ③Press “OFF” to exit the bypass voltage lower limit setting and goes to bypass upper limit setting.

7) Buzzer Mute Setting

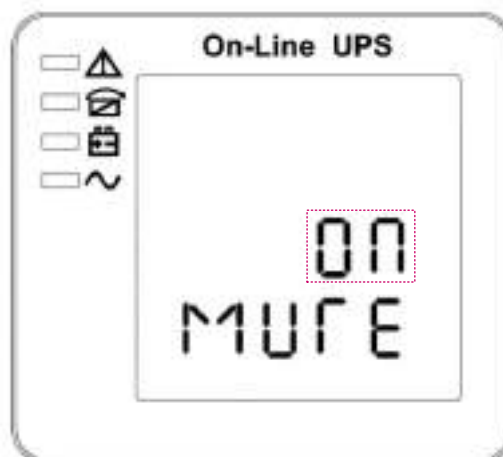

Buzzer Settings (note: red dashed box is the scintillation part)

In the bypass voltage low limit setting press “ON” or in battery self-test setting press “OFF”, it goes to buzzer setting. The scintillation of setting

state shows as the figure (Note: ON shows MUTE, OFF shows NO MUTE). ①Press button “ $\cup$ ” for Mute Cycle Settings, mute choice has On and Off. ②Press button “ON” exits mute setting and save mute setting state and change to battery self-test settings. ③Press button “OFF” exits mute setting and change to bypass voltage lower limit setting.

- 8) Periodical battery self-test Setting

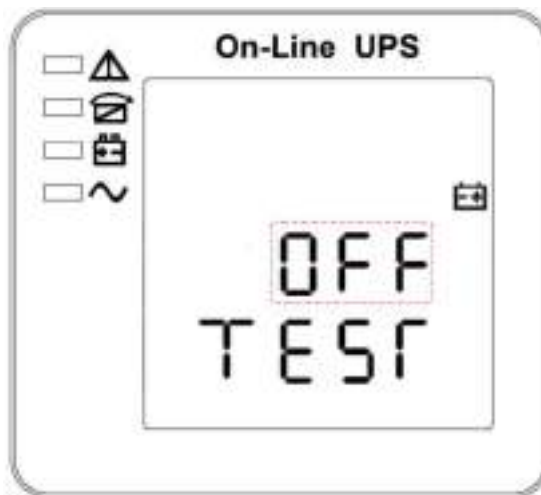

Periodical battery self-test setting (note: the part in dashed box flashes)

In the buzzer setting press “ON” or in parallel ID setting press “OFF”, it goes to the battery self-test setting. In the meantime the setting state flashes as above picture shows (Note: ON 1- the battery self-test function is enabled, UPS will do self-test 10 seconds every 30 days; ON 2- the battery self-test function is enabled, UPS will do self-test 10 minutes every 30 days; ON 3- the battery self-test function is enabled, UPS will do self-test till battery voltage reaches EOD point every 30 days; OFF-battery self-test function is disabled.). ①Press “ $\cup$ ” to set periodically self-test setting. The options are OFF, ON 1, ON 2 and ON 3. ②Press “ON” to exit Periodically Self-test setting and save the setting value, and goes to battery temperature compensation sensor switch setting. ③Press “OFF” to exit Periodically Self-test setting and goes to buzzer setting.

- 9) Battery temperature compensation sensor switch setting

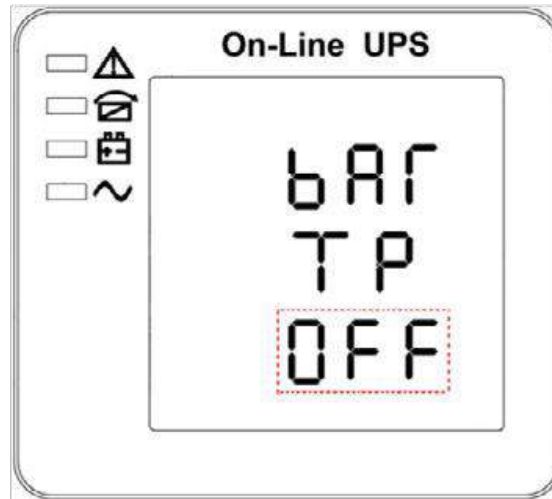

Battery temperature compensation sensor switch setting(Note: the information in the red box will be flashing)

Press "ON" under the periodical battery self-test setting or press "OFF" under device address setting, goes to the battery temperature compensation switch setting. The setting state flashes as above picture shows (Note: OFF means turn off the sensor switch, ON means turn on the sensor switch, send query command to sensor with address 11,12 every second. ①Press "ON" is to set the battery sensor, with options OFF & ON. ②Press "ON" to exit the battery sensor setting and save the battery sensor setting value and transfer to device address setting. ③ Press "OFF" to exit the battery sensor setting and transfer to battery periodical battery self-test setting.

#### 10) Device address setting

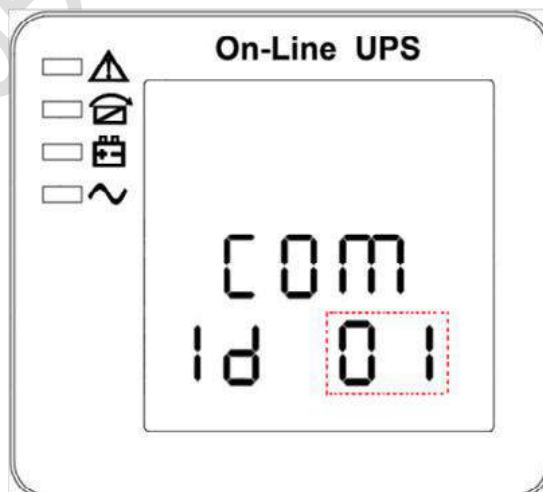

Device address setting(Note: the information in the red box will be flashing)

Press "ON" under the battery temperature compensation sensor switch setting or press "OFF" under parallel ID setting, goes to the device address setting. The setting state flashes as above picture shows (Note:

device address is 1~15, it is the MODBUS device address at RS232 & RS485 communication ports. ① Press “ $\cup$ ” to set the address, with options 1~15. When battery temperature sensor is open, can choose 1~10 & 13~15; If it's parallel mode and device address  $\leq$  parallel quantity, device address = parallel ID. ② Press “ON” to exit the device address setting and save the device address setting value and parallel ID setting. (Note: Under single UPS mode, until this device address setting save and exit, single UPS setting is done.) ③ Press “OFF” to exit the device address setting and transfer to battery temperature compensation sensor setting.

11)

Parallel ID setting

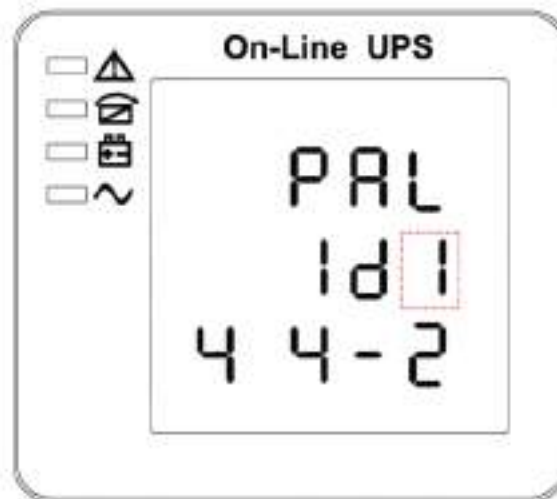

Parallel ID setting (Note: Inside the broken-line is the flashing part.)

When in device address setting press “ON” or when under parallel quantity setting press “OFF”, it goes to the parallel ID setting. The parallel ID flashes as in above picture. ① Use button “ $\cup$ ” to set the different parallel ID. The parallel ID range is 1~4. ② Press “ON” to exit the parallel ID setting and save the parallel ID setting value and goes to parallel quantity setting. ③ Press “OFF” to exit the parallel ID setting and goes to device address setting.

**CAUTION!**

Parallel cable cannot be connected when setting the parallel parameters.

12)

Parallel quantity setting

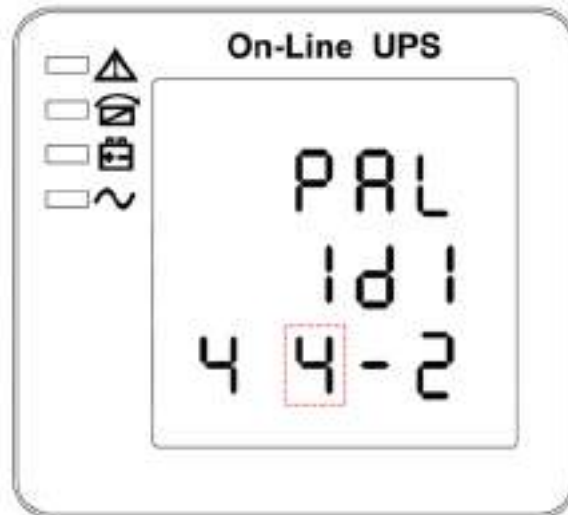

Parallel quantity setting (Note: Inside the broken-line is the flashing part.)

When under the parallel ID setting press "ON" or when under parallel redundancy quantity setting press "OFF", it goes to the parallel quantity setting. The parallel quantity flashes as in above picture. ①Use button "U" to set the parallel quantity. The parallel quantity range is 2~4. ②Press "ON" to exit the parallel quantity setting and save the parallel quantity setting value and goes to parallel redundancy quantity setting. ③Press "OFF" to exit the parallel quantity setting and goes to parallel ID setting.

13) Parallel redundancy quantity setting

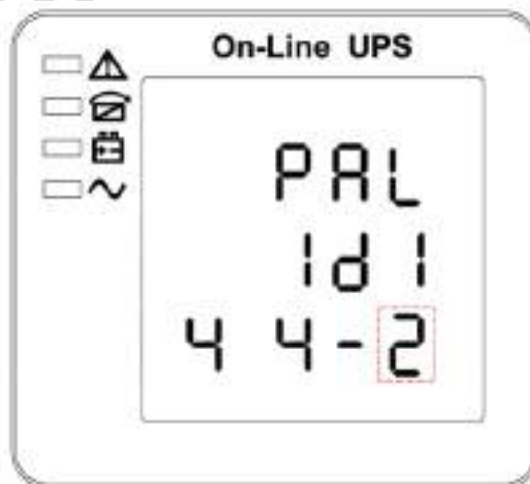

Parallel redundancy quantity setting (Note: Inside the broken-line is the flashing part.)

When under the parallel quantity setting press "ON", it goes to the parallel redundancy quantity setting. The parallel redundancy quantity flashes as in

above picture. ①Use button “ $\cup$ ” to set the parallel redundancy quantity. The parallel redundancy quantity range is 0~3. ②press “ON” to exit the mode setting and save the mode setting value and then UPS LCD panel setting is accomplished. ③Press “OFF” to go to parallel quantity setting.

### 13 Parallel system commissioning

**Warning:** When UPS is working, the internal Bus capacitor stores a lot of energy. But isolated with mains cannot guarantee completely no electricity inside the UPS and need extra attention when do the maintenance. When cut off all the external input power supplied for maintenance, use the bleed resistor to release the energy stored in Bus capacitor after open the case firstly to avoid causing injury to persons.

Please refer to the “UPS repair/maintenance”, especially the “Security maintenance conditions” and “Close-Disassembly/Reassembly UPS”.

Parallel system should be commissioning when the stand-alone are all intact.

#### 13.1 Boost steps

take 4 units in parallel for example

- 1) Confirm the input/output wires connection and input phase sequence are correct; switch off the battery breaker, and measure the +/- bat voltage of all battery ground are normal.
- 2) Connect the parallel cable, it should be formed loop connection.
- 3) Switch on the input breaker of unit 1, and access LCD setting interface to setting the working mode, ID, parallel number, redundant number. The setting interface is showed as below, require setting the in series number, capacity of battery. The output voltage level and Bypass protection range are default setting.

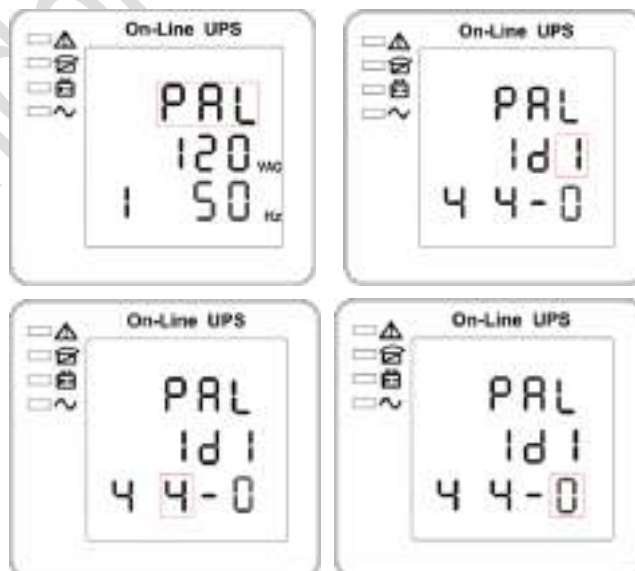

- 4) Turn off the input breaker of Unit 1, and make sure the UPS is off. Turn on the input breaker of Unit 2, access the LCD setting interface, setting the parallel working mode, ID(NO 2), parallel 2 units, redundant number. The other settings are the same as UPS 1 operation.

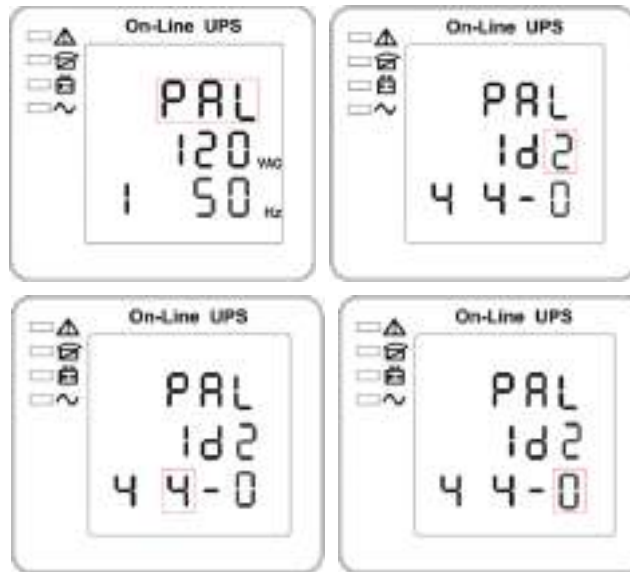

- 5) For Unit 3 and Unit 4 UPS , the operation setting are all the same as Unit 1 and 2.
- 6) Turn on Bypass/input/output breaker of all the paralleled UPS , then confirm all the setting are correct. Each UPS has their owed different ID.
- 7) There are only one master in parallel system .The one has a dot behind parallel mode is the master. You can turn on all the UPS after confirm all the setting are correct.

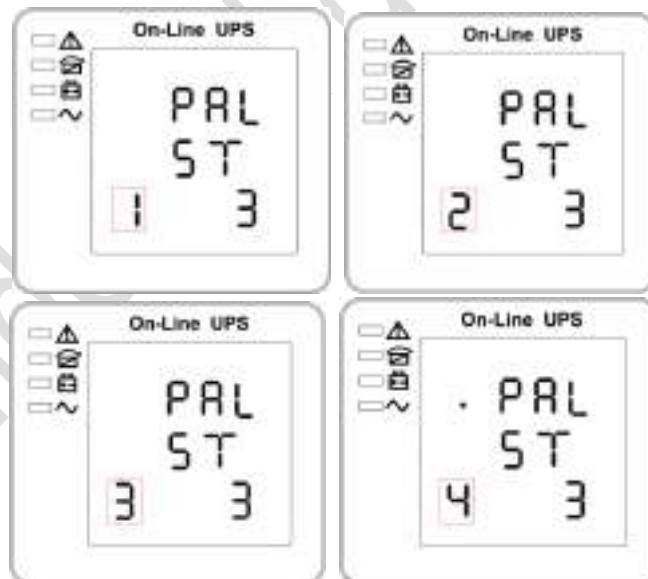

- 8) Turn on all the battery breaker and confirm the parameter (V/I)are normal.
- 9) Connected the Load, and check whether the output current are balance .
- 10) Switch on and off the utility breaker to test all the UPS converters system from Utility to battery and restored function are working find.

### 13.2 Shutdown steps

- 1) Confirm the load information to avoid overload when turn off single unit;
- 2) Shut down each UPS according to the stand-alone UPS shutdown steps.

### 13.3 Emergency shutdown

Connect all the EPO ports to a key switch according to the following figure. When emergency occurs, switch on the key can turn off all the outputs of UPS in this parallel system.

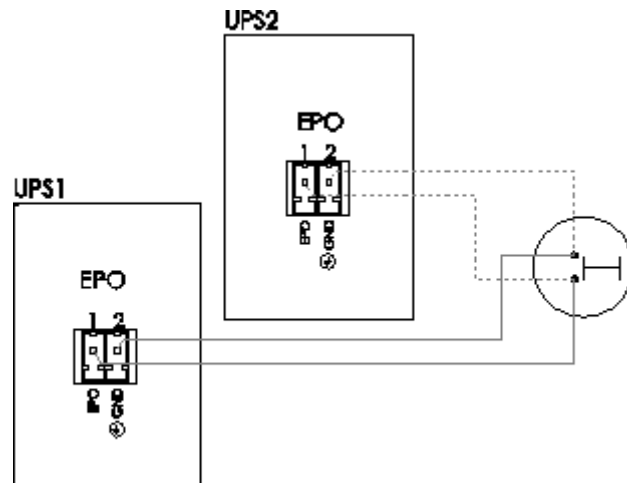

## 14 Software upgrade

There are two methods for software upgrade.

### 14.1 Use C2000 emulator to upgrade

When shutdown the UPS, remove the right panel of UPS, burn the DSP in control detection board separately to upgrade. For detailed steps, please refer to the C2000 simulator instruction.

### 14.2 Use RS232 port to realize online upgrade

14.2.1.1 Remove the panel of the maintenance breaker, turn on the breaker so that the UPS goes to maintenance bypass mode.

14.2.1.2 Turn on the UPS with utility. Open the serial program software Prg2800\_33.exe



Note:

- a) When burning is finished, the other DSP cannot be burned until the DSP buzz. ( after burning INV, about 5S later, the next burning can be performed. When finish burning the REC, the next burning can be executed after about 20s).
- b) If it fails during the REC burning, it will show “ Program was

unsuccessful". Switch off the UPS and then restart, click "Update" to re-burn.

c) If it fails during the INV burning, it will show "Program was unsuccessful". Switch off the UPS and then restart, modify the ID number to 1 in the software. Close the serial port and then open it, click "Re-Update" to start the re-burning.

d) During the burning, it repeats a frame data which goes into an infinite loop. Restart the UPS and Prg2800\_33 and check if the communication connection is ok. Then re-burn can be operated. If it is the REC burning, please refer to the item b, if INV burning, please refer to item c.

e) If the REC and INV burning are both fail, the INV burning (Re-Update) has to be operated firstly. Cut off the mains and then power on the UPS, then the REC burning (Update) can be executed.

#### 14.2.1.3 Follow the settings in Figure (1)

"1" is to choose serial port that the computer uses;

"2" choose speed 9600;

"3" choose RS232;

"4" is to choose the ID number for the UPS that we are programmed. For single unit, it's ID1, for parallel unit, it's the same as the ID number as we set in the UPS LCD.

"5" for laptop, pls set the value  $\geq 5$ ; for desktop computer, can set the value  $< 5$ ;

"6" choose 07;

"7" choose INV for the program, because we are going to update the inverter program; the same is REC program.

"8" is default value, no need to change;

"10" is for the target software "INV33.out" that we are going to program. pls note that you have to click "11" to choose target upgrade file

#### 14.2.1.4 After the setting done, pls click "Open device" as shown in Fig (1)

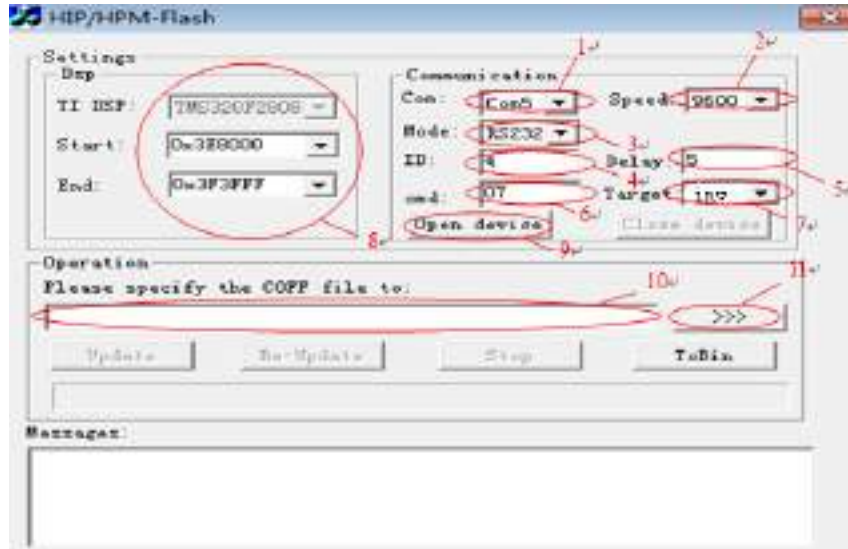

Figure(1)

14.2.1.5 After the above steps, it shows below Fig (2), pls click the “OK” button

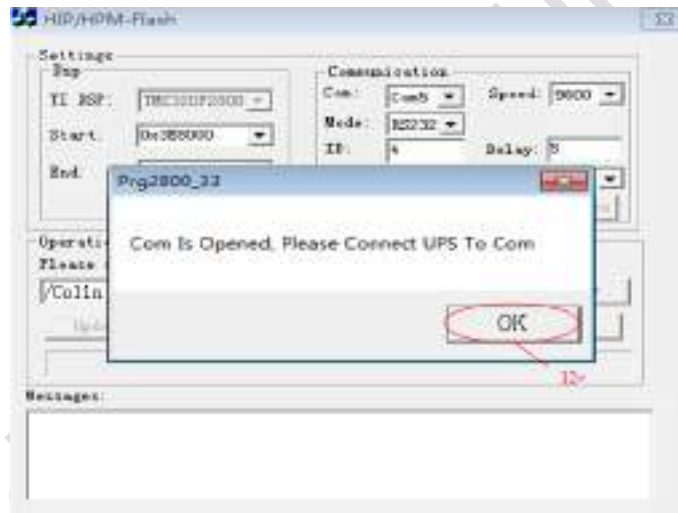

Figure(2)

14.2.1.6 Connect the UPS RS232 to the computer’s serial port, make sure the communication between them is good

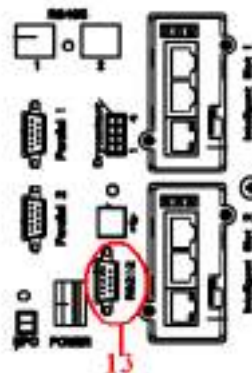

Figure(3)

14.2.1.7 After set up the communication between UPS and computer, click “Update” as

shown in Figure (4)



Figure(4)

14.2.1.8 Figure (5) shows the chip is preparing for the program

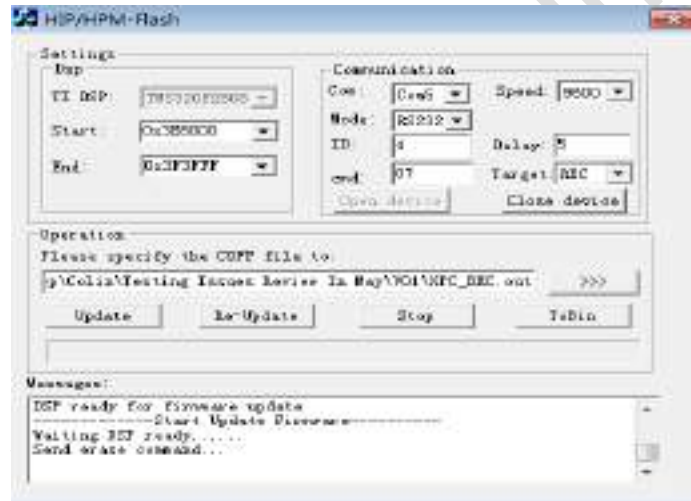

Figure(5)

14.2.1.9 Figure (6) shows the program work is proceeding



Figure(6)

14.2.1.10 Follow below Figs 7/8/9 to finish and exit.

If need go on the programming, pls return to step 3.

If finish and stop the programming, pls turn OFF the maintenance breaker, put on the panel, work the UPS to inverter power supply.



Figure(7)



Figure(8)



Figure(9)

## Appendix A UPS fault judgment

NO.	UPS Alarm	Software judgment				Buzz	LED
		Condition 1	Condition 2	Condition 3	Condition 4		
1	Rectifier fault	DC BUS over-voltage	DC BUS under-voltage	Large bus difference		long beep	Fault ON
2	Inv. fault(include Inv. Bridge arm )	The absolute value of the output voltage >112.5% of rated output voltage, last 500ms		Bridge arm midpoint voltage( Inv. voltage) last 500ms>1.1 time of rated peak value 360Vfor230 344for220 376for240		long beep	Fault ON
3	Inv. SCR short					long beep	Fault ON
4	Inv. SCR break	(in parallel, X phase load rate<6.3%) &&(parallel X phase total load rate>50%) &&(large loop current     in bypass mode) last time 2S				long beep	Fault ON
5	Bypass SCR short	(X phase Output voltage>60% of rated) &&(the absolute values of other phases voltage<5% of rated voltage) last 2s				long beep	Fault ON
6	Bypass SCR break	((in parallel, X phase load rate <6.3%) &&(parallel X phase total load rate> 50%) &&(large loop current     in Bypass mode) )    (X phase current<10% of rated&&X phase Output voltage<50% of the Bypass voltage) last 2S				long beep	Fault ON
7	Fuse broken	Hardware signal low available				long beep	Fault ON
8	Parallel Relay fault	( Inv. status&&Relay open)    (no Inv. Status && parallel Relay close) last 20ms				long beep	Fault ON
9	Fan fault	Hardware signal low available for 5s				long beep	Fault ON
10	Reserve					long beep	Fault ON
11	Auxiliary power fault	Hardware signal low available for 3ms				long beep	Fault ON
12	Power initialization fault	1) Rec.DSP read IIC self-test, until 15s power on) Inv. DSP read IIC self-test, until 15s delay unit not obtain valid parameter from E2PROM, jumper error, jumper type is not defined, DSP internal RAM self-test error(MCU cannot completely modify RAM)				long beep	Fault ON

NO.	UPS Alarm	Software judgment				Buzz	LED
		Condition 1	Condition 2	Condition 3	Condition 4		
13	Positive battery Charge fault					long beep	Fault ON
14	Negative battery Charge fault					long beep	Fault ON
15	Bus over-voltage	+bus voltage > 470V Last time: 20ms	-bus voltage > 470V Last time: 20ms			long beep	Fault ON
16	Bus under-voltage	Bus voltage < 280V time: 120ms	Bus voltage is 10V lower than setting value Time: 2min			long beep	Fault ON
17	Large difference between ±Bus	30V difference between ±bus				long beep	Fault ON
18	Soft start fail	10s later, soft start bus voltage is lower than 300V	During the soft start, ±bus voltage < 1.2 times of input voltage for 120ms			long beep	Fault ON
19	Rectifier over-temperature	Last 0.2s > 77°C show PFC over temperature				twice/s	Fault ON
20	Inv. Over-temperature	Last 0.2s > 77°C show inverter over temperature				twice/s	Fault ON
21	Reserve					twice/s	Fault ON
22	Battery reverse	+battery voltage < -50V	-battery voltage > +50V			twice/s	Fault ON
23	Parallel connection fault	Parallel cable fault under the parallel : 10ms				twice/s	Fault ON
24	CAN communication fault	Parallel number more than 1 for single unit and powered UPS is no more than 1 unit				twice/s	Fault ON
25	Share current when parallel fault					twice/s	Fault ON
26	Battery high voltage	Setting Charge voltage +20V				once/s	Fault flash
27	Input phase sequence reverse	Obtain by algorithm				once/s	Fault flash
28	Bypass reverse	Obtain by algorithm				once/s	Fault flash
29	Output short circuit	X phase Output voltage is lower than rated 30% & X phase Output current is 70% of rated current				once/s	Fault flash

NO.	UPS Alarm	Software judgment				Buzz	LED
		Condition 1	Condition 2	Condition 3	Condition 4		
30	Rectifier over-current					once/s	Fault flash
31	Bypass over-current	X phase Bypass Output current greater than the rated 125%				once/s	BPS flash
32	Over load	X phase load rate( Inv. or Bypass) greater than rated 105%				once/s	INV or BPS flash
33	No battery	Battery voltage lower than 50V				once/s	BATTERY flash
34	Battery voltage low	Battery voltage lower (EOD voltage*6*battery pcs)				once/s	BATTERY flash
35	Low battery pre-alarm	Battery EOD voltage+(battery pcs *6(SetJarNum) *1.5)				once/s	BATTERY flash
36	Internal communication error	Comm. Error between Rectifier and Inv.				once/2s	Fault flash
37	Inv. DC excessive	DC component average value is more than 2V last 2S				once/2s	INV flash
38	Overload in parallel	X phase load rate is more than total load rate of parallel system: 400ms				once/2s	INV flash
39	Mains voltage abnormal	Higher than 270V	Lower than 182V			once/2s	BATTERY ON
40	Mains frequency abnormal	Higher than 70Hz	Lower than 38Hz			once/2s	BATTERY ON
41	Bypass ultra protection	Bypass power down and not available					BPS flash
42	Bypass ultra tracking	Bypass abnormal but powered, and bypass instantaneous normal, then change the Bypass to ultra tracking					BPS flash
43	Start invalid	1) rectifier not start completely or start fault a) over-temperature b) fan fault c) SCR fault and shutdown d) bridge arm short and shutdown e) power board fault f) software fail					

NO.	UPS Alarm	Software judgment				Buzz	LED
		Condition 1	Condition 2	Condition 3	Condition 4		
		g) battery reverse and shutdown h) user operation fault(maint. Bypass close) i) Auxiliary power power down and shutdown 2) manually start invalid					
44	Reserve						
45	Inverter not on						
46	Output switch not ON					Once per 3 seconds	

Confidential document